

Ball and Roller Bearings

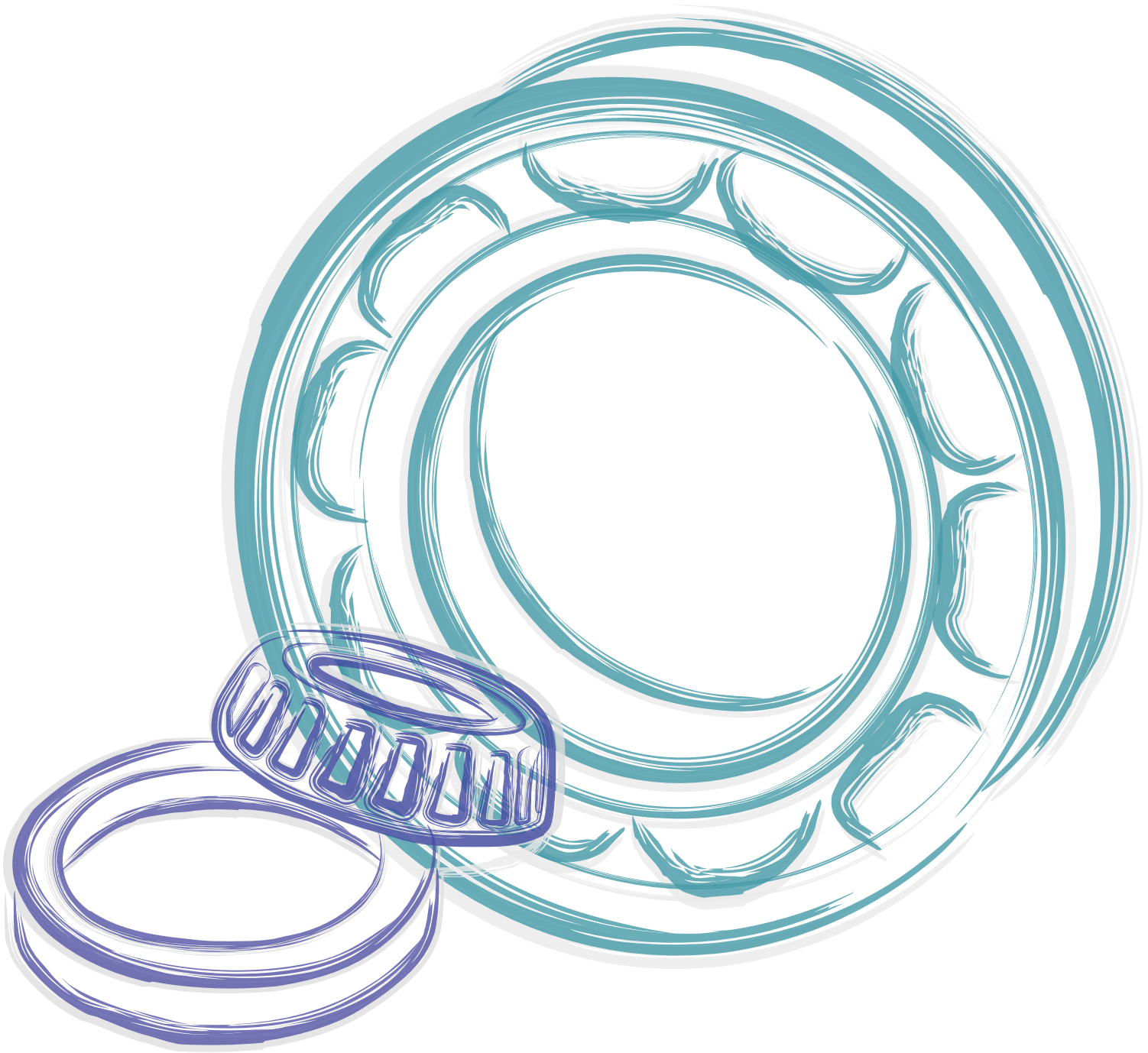

Ball and Roller Bearings



Contents

- 05 BEARING GENERAL INFORMATION
- 13 SINGLE-ROW DEEP GROOVE BALL BEARING
- 33 TAPERED ROLLER BEARING



GMB

BEARING GENERAL INFORMATION

Deep groove ball bearings

Deep groove ball bearings are available in a variety of sizes, and are the most popular of all rolling bearings. This type of bearing supports radial load and a certain degree of axial load in both directions simultaneously.

Shielded / sealed type

- Simplifies sealing structure of applications.
- Greasing is not necessary because bearings are pre-lubricated.
- Table 1 on the next page lists major shielded and sealed bearing types and compares their performance.

With locating snap ring

- Bearings with a locating snap ring can be fit to the housing easily, as the locating snap ring facilitates axial positioning.

Extra-small ball bearings and miniature ball bearings

- The open type is widely used. Also available are the shielded / sealed type and the flanged type; the latter is easily positioned in the axial direction.

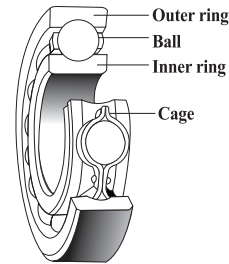

Deep groove ball bearing

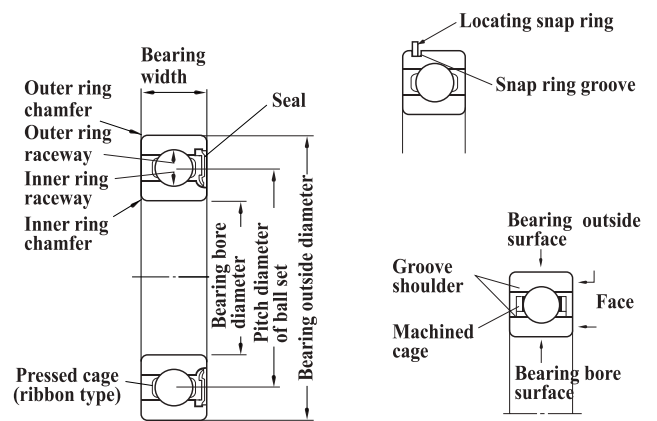





Comparison of shielded and sealed bearing performance

Type	Shielded		Sealed	
	Non-contact type	Non-contact type	Contact type	
	ZZ type	2RU type	2RS type	
Characteristics	 (a) ¹⁾ (b)	 (b)	 (d) ²⁾ (e)	
Friction torque	Small	Small	Large	
High speed performance	Good	Good	Limited because of contact	
Grease sealing property	Good	Better than ZZ type	Better than 2RU type for low-speed applications	
Dirt resistance	Good	Better than ZZ type	Better than 2RU type	
Water resistance	Economical	Better than ZZ type but inferior to 2RS, 2RK and 2RD types	Good	
Operating temperature ³⁾	-30 to +110°C		-30 to +100°C	

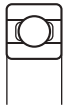
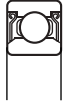
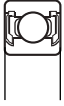
- Notes**
- 1) Illustration (a) of the ZZ type shows the relatively small size bearing.
 - 2) Illustration (d) of the 2RS type shows the relatively small size bearing.
 - 3) The operating temperature range listed is for the standard type. It can be widened by using a different type of grease or sealing material.

● Deep groove ball bearings

Single - row					Double - row
Open type	Shielded type	Non - contact sealed type	Contact sealed type	With locating snap ring	
	 ZZ	 2RU	 2RS	 NR	
680, 690, 600, 620, 630, (ML), (OB) 6800, 6900, 6000, 6200, 6300 Extra-small, miniature bearing					5203 (Angular contact)
[Recommended cages] Pressed steel cage (ribbon type, snap type ... single - row, S type ... double - row), copper alloy or phenolic resin machined cage, synthetic resin molded cage					
[Main applications] Automobile : front and rear wheels, transmissions, electric devices Electric equipment : standard motor, electric appliances for domestic use Others : measuring instruments, internal combustion engines, construction equipment, railway rolling stock, cargo transport equipment, agricultural equipment, equipment for other industrial uses					hydraulic pumps, roots blowers, air-compressors, transmissions,

- The most popular types among rolling bearings, widely used in a variety of industries.
- Radial load and axial load in both directions can be accommodated.
- Suitable for operation at high speed, with low noise and low vibration.
- Sealed bearings employing steel shields or rubber seals are filled with the appropriate volume of grease when manufactured.
- In spite of having the same boundary dimensions as standard bearings, maximum type bearings have a higher load rating because a filling slot on each of the inner and outer rings, allows a greater number of balls to be inserted than do standard bearings.
- Angular contact ball bearings are used for high accuracy and high-speed operation.

Bearing materials

Bearing materials include steel for bearing rings and rolling elements, as well as steel sheet, steel, copper alloy and synthetic resins for cages.

These bearing materials should possess the following characteristics :

- | | | |
|--|---|--|
| 1) High elasticity, durable under high partial contact stress. | } | Bearing rings
Rolling elements |
| 2) High strength against rolling contact fatigue due to large repetitive contact load. | | |
| 3) Strong hardness | } | Bearing rings
Rolling elements
Cages |
| 4) High abrasion resistance | | |
| 5) High toughness against impact load | | |
| 6) Excellent dimensional stability | | |



Bearing ring and rolling element materials

High carbon chrome bearings steel

High carbon chrome bearing steel specified in **KS(Korean Standard)** or **JIS(Japanese Industrial Standard)** is used as a general material in bearing rings (inner rings, outer rings) and rolling elements (balls, rollers) Their chemical composition classified by steel type is given in Table shown below.

Chemical composition of high carbon chrome bearing steel

Standard	Code	C	Si	Mn	P	S	Cr	Ni	Mo
KOREA KS D 3525	STB 2	0.95~1.10	0.15~0.35	≤0.50	≤0.025	≤0.025	1.30~1.06	≤0.25	≤0.08
	STB 3	0.95~1.10	0.40~0.70	0.9~1.15	≤0.025	≤0.025	0.90~1.20	≤0.25	≤0.08
	STB 4	0.95~1.10	0.15~0.35	≤0.50	≤0.025	≤0.025	1.30~1.06	≤0.25	0.10~0.25
JAPAN JIS G 4805	SUJ 1	0.95~1.10	0.15~0.35	≤0.50	≤0.025	≤0.025	0.90~1.20	≤0.25	≤0.08
	SUJ 2	0.95~1.10	0.15~0.35	≤0.50	≤0.025	≤0.025	1.30~1.06	≤0.25	≤0.08
	SUJ 3	0.95~1.10	0.40~0.70	0.9~1.15	≤0.025	≤0.025	0.90~1.20	≤0.25	≤0.08
	SUJ 4	0.95~1.10	0.15~0.35	≤0.50	≤0.025	≤0.025	1.30~1.06	≤0.25	0.10~0.25
	SUJ 5	0.95~1.10	0.40~0.70	0.9~1.15	≤0.025	≤0.025	0.90~1.20	≤0.25	0.10~0.25
U.S.A.AISI SAE J405	E51100	0.98~1.10	0.20~0.35	0.25~0.45	≤0.025	≤0.025	0.90~1.15	≤0.25	≤0.08
	E52100	0.98~1.10	0.20~0.35	0.25~0.45	≤0.025	≤0.025	1.30~1.60	≤0.25	≤0.08
CHINA YJZ 84	GCr 15	0.95~1.05	0.15~0.35	0.25~0.45	≤0.027	≤0.02	1.40~1.65	≤0.23	≤0.1
Germany VDEH (German Iron & Steel Association)	105Cr2	1.00~1.10	0.15~0.35	0.25~0.40	≤0.030	≤0.025	0.40~0.60	-	-
	105Cr2	1.00~1.10	0.15~0.35	0.25~0.40	≤0.030	≤0.025	0.90~1.15	-	-
	100Cr2	0.90~1.05	0.15~0.35	0.25~0.40	≤0.025	≤0.020	1.40~1.65	-	-
	100CrMin6	0.90~1.05	0.50~0.70	1.00~1.20	≤0.025	≤0.020	1.40~1.65	-	-

unit : %

Chemical compositions of pressed cage steel

unit : %

Standard	Code	C	Si	Mn	P	S
KOREA KS D 3512	SCP 1	≤ 0.10	≤ 0.04	0.25~0.45	≤ 0.03	≤ 0.03
	SCP 2	0.13~0.20	≤ 0.04	0.25~0.50	≤ 0.03	≤ 0.03
	SCP 3	0.45~0.55	0.15~0.35	0.40~0.85	≤ 0.03	≤ 0.03
JAPAN BAS 361	SPB 1	≤ 0.10	≤ 0.04	0.25~0.45	≤ 0.03	≤ 0.03
	SPB 2	0.13~0.20	≤ 0.04	0.25~0.50	≤ 0.03	≤ 0.03
	SPB 3	0.45~0.55	0.15~0.35	0.40~0.85	≤ 0.03	≤ 0.03
U.S.A.SAE J 403g J 118 J 403g	1008	≤ 0.0	≤ 0.10	0.30~0.50	≤ 0.04	≤ 0.05
	1009	≤ 0.15	≤ 0.10	≤ 0.60	≤ 0.04	≤ 0.05
	1010	0.08~0.13	≤ 0.10	0.30~0.60	≤ 0.04	≤ 0.05

Lubricants

Correct lubrication is critical to bearing performance, reducing friction, dissipating heat and inhibiting corrosion on balls and raceways. The lubricant will affect maximum running speed and temperature, torque level, noise level and, ultimately, bearing life. Lubricants are available for a whole range of applications.

Bearing lubrication is classified broadly into two categories: grease lubrication and oil lubrication. Table 12-1 makes a general comparison between the two.

Comparison between grease and oil lubrication

Item	Grease	Oil
Sealing device	Easy	Slightly complicated and special care required for maintenance
Lubricating ability	Good	Excellent
Rotation speed	Low / medium speed	Applicable at high speed as well
Replacement of lubricant	Slightly troublesome	Easy
Life of lubricant	Relatively short	Long
Cooling effect	No cooling effect	Good (circulation is necessary)
Filtration of dirt	Difficult	Easy

Grease is an oil to which a thickener has been added to prevent migration from the lubrication site, resulting in longer life. It is used in situations where frequent replenishment of the lubricant is undesirable or impossible.

The operative properties of grease depend almost wholly on the choice of base oil.

Characteristics of respective greases

	Lithium grease			Calcium grease (cup grease)	Sodium grease (fiber grease)
Thickener	Lithium soap			Calcium soap	Sodium soap
Base Oil	Mineral oil	Synthetic oil (diester oil)	Synthetic oil (silicon oil)	Mineral oil	Mineral oil
Dropping point (°C)	170 to 190	170 to 230	220 to 260	80 to 100	160 to 180
Operating temperature range (°C)	-30 to +120	-50 to +130	-50 to +180	-10 to +70	0 to +110
Rotation speed range	Medium to high	High	Low to medium	Low to medium	Low to high
Mechanical stability	Excellent	Good to excellent	Good	Fair to good	Good to excellent
Water resistance	Good	Good	Good	Good	Bad
Pressure resistance	Good	Fair	Bad to fair	Fair	Good to excellent
Remarks	Most widely usable for various rolling bearings.	Superior low temperature and friction characteristics. Suitable for bearings for measuring instruments and extra - small ball bearings for small electric motors.	Superior high and low temperature characteristics.	Suitable for applications at low rotation speed and under light load. Not applicable at high temperature.	Liable to emulsify in the presence of water. Used at relatively high temperature.

	Complex base grease		Non - soap base grease		
Thickener	Lithium complex soap	Calcium complex soap	Bentone	Urea compounds	Fluorine compounds
Base Oil	Mineral oil	Mineral oil	Mineral oil	Mineral / synthetic oil	Synthetic oil
Dropping point (°C)	250 or higher	200 to 280	-	240 to higher	250 or higher
Operating temperature range (°C)	-30 to +150	-10 to +130	-10 to +150	-30 to +150	-40 to +250
Rotation speed range	Low to high	Low to medium	Medium to high	Low to high	Low to medium
Mechanical stability	Good to excellent	Good	Good	Good to excellent	Good
Water resistance	Good to excellent	Good	Good	Good to excellent	Good
Pressure resistance	Good	Good	Good to excellent	Good to excellent	Good
Remarks	Superior mechanical stability and heat resistance. Used at relatively high temperature.	Superior pressure resistance when extreme pressure agent is added. Used in bearings for rolling mills.	Suitable for applications at high temperature and under relatively heavy load.	Superior water resistance, oxidation stability, and heat stability. Suitable for applications at high temperature and high rotation speed.	Superior chemical resistance and solvent resistance. Usable at up to 250°C.

Manufacturer	Brand	Thickener	Base oil	Drop point °C	Consistency	Temperature range °C	
Esso	Beacon 325	Lithium	Diester	193	290	-60 ~ +120	
	AC 205	Nathium	Mineral			-25 ~ +120	
	Andok B	Nathium	Mineral	260	280	-40 ~ +120	
	Andok C	Nathium	Mineral	≥260	205	-20 ~ +120	
	Andok 260	Nathium	Mineral	200	250	-30 ~ +150	
	Andok RB 300	LithiumCalcium	Mineral	175	300	-30 ~ +100	
	NS Hilube	Lithium	Diester	190	255	-40 ~ +130	
	Multemp PS2	Lithium	Diester	189	280	-50 ~ +110	
	Multemp SRL	Lithium	Ester	191	245	-40 ~ +150	
	Multemp SC-A	Urea		≥260	280	0 ~ +160	
	Multemp ET150	Urea	Mineral	≥260	280	-10 ~ +160	
	Oneluba	Lithium	Diester Mineral	198	370	-10 ~ +110	
	Adrex	Lithium	Mineral	198	300	-10 ~ +120	
	Parmax		Mineral	180	300	-10 ~ +120	
	Emalibe 1130	Urea	Mineral	≥260	300	-10 ~ +130	
	Unilube DL1	Lithium	Mineral	185	332	-10 ~ +110	
	Alumix HD1		Mineral	247	335	0 ~ +120	
Kluber	Staburage NBU12	Barium	Mineral	220	270	-35 ~ +150	
	IsoflexNBU15	Barium	Diester Mineral	220	280	-60 ~ +130	
	AsonicGLY32	Lithium	synthetic			-50 ~ +140	
	AsonicGHY72	Polyhamstoff	Ester Mineral			-40 ~ +130	
	Isoflex super LDS18	Lithium	Diester	190	280	-60 ~ +130	
	Isoflex super TEL	Lithium	Ester Mineral			-65 ~ +70	
	Isoflex LDS18 Spezial A	Lithium	Diester	190	280	-60 ~ +130	
	Isoflex PDB38 CX100	Lithium	Ester			-70 ~ +120	
	Isoflex Topas NB52	Barium	Synthetic hydrocarbon	240	280	-60 ~ +170	
	Barrierta L55/2	Fluorotelomer	Fluorinated		280	-35 ~ +260	
	Barrierta EL	Fluorotelomer	Fluorinated		280	-50 ~ +180	
	Barrierta IMI/V	Fluorotelomer	Fluorinated			-50 ~ +220	
Unsilikon TK44N2	Na-komplex	Silicone		280	-60 ~ +230		
Dow Corning	Molykote 33M	Lithium	Silicone	210		-70 ~ +180	
	Molykote 44M	Lithium	Silicone	204		-40 ~ +200	
	Molykote 55M	Lithium	Silicone		260	-55 ~ +165	
	Molykote BR2 plus	Lithium	Mineral		260	-30 ~ +150	
	Molykote FS1292	Fluorotelomer	Phlorosicone	≥232		-40 ~ +200	
	Molykote FS3451	Fluorotelomer	Phlorosicone	≥260	280	-40 ~ +230	
Shell	Alvania No.2	Lithium	Mineral	182	310	-25 ~ +120	
	Alvania No.3	Lithium	Mineral	183	285	-20 ~ +135	
	Alvania RA	Lithium	Mineral	183	272	-25 ~ +120	
	Alvania EP2	Lithium	Mineral	185	233	-10 ~ +100	
	Sunlight 2	Lithium	Mineral	196	252	-20 ~ +120	
	Dolium R		Mineral	238	276	-20 ~ +140	
	Aero shell NO.5	Microgel	Mineral	≥260	273	-10 ~ +130	
	Aero shell NO.7	Microgel	Diester	≥260	281	-70 ~ +150	
	Aero shell NO.15A	Fluorotelomer	Silicone	≥260	282	-70 ~ +260	
Mobil Oil	Mobilux2	Lithium	Mineral	190	288	-20 ~ +120	
	Mobigrease 22	Lithium	Diester Mineral	192	280	-50 ~ +140	
	Mobigrease 28	Bentonite	Synthetic hydrocarbon	≥260	280	-60 ~ +180	
	Mobilpex 47		Mineral	≥260	274	-20 ~ +120	
Du Pont	Krytox 240AC	Fluorotelomer	Fluorinated		280	-35 ~ +280	
	Krytox 283AC	Fluorotelomer	Fluorinated		280	-35 ~ +280	
	Krytox 143AC	Fluorotelomer	Fluorinated		282	-35 ~ +280	
Toray Silicone	SH44M	Lithium	Silicone	210	229	-40 ~ +180	
	SH33L	Lithium	Silicone	210		-70 ~ +140	
	SH41	Lithium	Silicone		260	-10 ~ +200	
Caltex	Chevron SRI-2	Urea	Mineral		300	-30 ~ +175	
General Electric	Anderol SRI-2	Lithium	Diester		280	-60 ~ +150	
	Versilube G-300	Lithium	Silicone		293	-70 ~ +230	
	Versilube F-50		Silicone			-70 ~ +230	

GMB

SINGLE-ROW DEEP GROOVE BALL BEARING



Single-row deep groove ball bearing Bore diameter 3~9mm

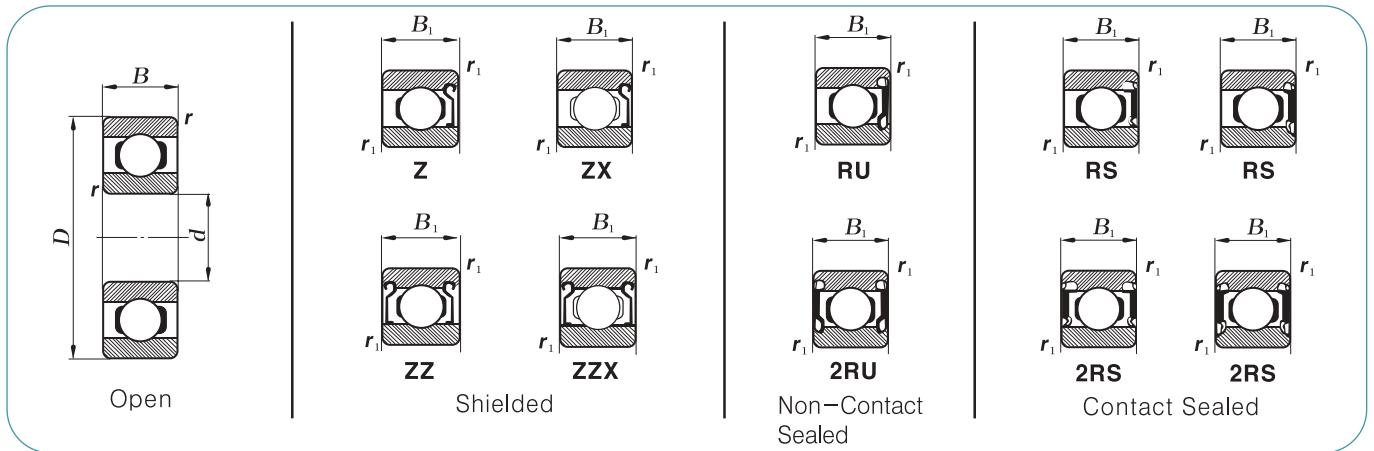

Boundary dimensions(mm)						Bearing No.						
d	D	B	B ₁	r _s ¹⁾	r _{1s} ¹⁾	Open	Shielded		Non-Contact Sealed		Contact Sealed	
				Min	Min		Z	ZZ	RU	2RU	RS	2RS
1	3	1	-	0.05	-	681	-	-	-	-	-	-
1	4	1.6	-	0.1	-	691	-	-	-	-	-	-
1.5	4	1.2	2	0.1	0.1	68/1.5	W68/1.5ZX	W68/1.5ZZX	-	-	-	-
1.5	5	2	2.6	0.15	0.15	69/1.5	W69/1.5ZX	W69/1.5ZZX	-	-	-	-
2	5	1.5	2.3	0.1	0.1	682	W682ZX	W682ZZX	-	-	-	-
2	6	2.3	3	0.15	0.1	692	W692ZX	W692ZZX	-	-	-	-
2	7	2.8	3.5	0.15	0.15	602	W602ZX	W602ZZX	-	-	-	-
2.5	6	1.8	2.6	0.1	0.1	6.8/2.5	W68/2.5ZX	W68/2.5ZZX	-	-	-	-
2.5	7	2.5	3.5	0.15	0.15	69/ 2.5	W69/2.5ZX	W69/2.5ZZX	-	-	-	-
3	7	2	3	0.15	0.15	683	W683ZX	W683ZZX	-	-	-	-
3	8	3	4	0.15	0.15	693	W693ZX	W693ZZX	-	-	-	-
3	9	3	5	0.15	0.15	603	W603ZX	W603ZZX	-	-	-	-
3	10	4	4	0.15	0.15	623	623Z	623ZZ	-	-	623RS	623 2RS
3	13	5	5	0.2	0.2	633	633Z	633ZZ	-	-	-	-
4	9	2.5	4	0.15	0.15	684	W684Z	W684ZZ	-	-	-	-
4	11	4	4	0.15	0.15	694	694Z	694ZZ	-	-	-	-
4	12	4	4	0.2	0.2	604	604Z	604ZZ	-	-	-	-
4	13	5	5	0.2	0.2	624	624Z	624ZZ	624RU	624 2RU	624RS	624 2RS
4	16	5	5	0.3	0.3	634	634Z	634ZZ	-	-	-	-
5	11	3	5	0.15	0.15	685	W685Z	W685ZZ	-	-	-	-
5	13	4	4	0.2	0.2	695	695Z	695ZZ	-	-	-	-
5	14	5	5	0.2	0.2	605	605Z	605ZZ	605RU	605 2RU	605RS	605 2RS
5	16	5	5	0.3	0.3	625	625Z	625ZZ	-	-	-	-
5	19	6	6	0.3	0.3	635	635Z	635ZZ	635RU	635 2RU	635RS	635 2RS
6	13	3.5	5	0.15	0.15	686	W686Z	W686ZZ	-	-	-	-
6	15	5	5	0.2	0.2	696	696Z	696ZZ	696RU	696 2RU	696RS	696 2RS
6	17	6	6	0.3	0.3	606	606Z	606ZZ	606RU	606 2RU	606RS	606 2RS
6	19	6	6	0.3	0.3	626	626Z	626ZZ	626RU	626 2RU	626RS	626 2RS
6	22	7	7	0.3	0.3	636	636Z	636ZZ	636RU	636 2RU	636RS	636 2RS
7	14	3.5	5	0.15	0.15	687	W687Z	W687ZZ	-	-	-	-
7	17	5	5	0.3	0.3	697	697Z	697ZZ	697RU	697 2RU	697RS	697 2RS
7	19	6	6	0.3	0.3	607	607Z	607ZZ	607RU	607 2RU	607RS	607 2RS
7	22	7	7	0.3	0.3	627	627Z	627ZZ	627RU	627 2RU	627RS	627 2RS
7	26	9	9	0.3	0.3	637	637Z	637ZZ	637RU	637 2RU	637RS	637 2RS
8	16	4	5	0.2	0.2	688	W688Z	W688ZZ	-	-	-	-
8	19	6	6	0.3	0.3	698	698Z	698ZZ	698RU	698 2RU	698RS	698 2RS
8	22	7	7	0.3	0.3	608	608Z	608ZZ	608RU	608 2RU	608RS	608 2RS
8	24	8	8	0.3	0.3	628	628Z	628ZZ	628RU	628 2RU	628RS	628 2RS
8	28	9	9	0.3	0.3	638	638Z	638ZZ	638RU	638 2RU	638RS	638 2RS
9	17	4	5	0.2	0.2	689	W689Z	W689ZZ	-	-	-	-
9	20	6	6	0.3	0.3	699	699Z	699ZZ	699RU	699 2RU	699RS	699 2RS
9	24	7	7	0.3	0.3	609	609Z	609ZZ	609RU	609 2RU	609RS	609 2RS
9	26	8	8	0.6	0.6	629	629Z	629ZZ	629RU	629 2RU	629RS	629 2RS
9	30	10	10	0.6	0.6	639	639Z	639ZZ	639RU	639 2RU	639RS	639 2RS

- Remarks**
- 1) Minimally required measurement of Chamfer.
 - 2) Bearing No.634 is the same as former No.634~5.
 - 3) Bearing No.625 and 696 are the same as former No.625-5 and 696-2.

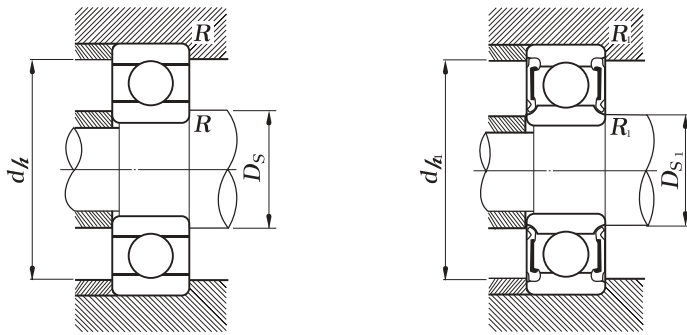

Dynamic equivalent radial load

$$P = XFr + YFa$$

$\frac{Fa}{Co}$	e	$\frac{Fa}{Fr} \leq e$		$\frac{Fa}{Fr} > e$	
		X	Y	X	Y
0.014	0.19	1	0	0.56	2.30
0.028	0.22				1.99
0.056	0.26				1.71
0.084	0.28				1.55
0.11	0.30				1.45
0.17	0.34				1.31
0.28	0.38				1.15
0.42	0.42				1.04
0.56	0.44				1.00

Static equivalent radial load

$$P_0 = 0.6Fr + 0.5Fa$$

If $P_0 < Fr$, $P_0 = Fr$

Basic Load Ratings(kgf)		Limiting Speeds(rpm)			Mounting Dimension(mm)							Weight (g)	Bearing No.
Dynamic C_e	Static C_o	Grease lub		Oil lub	Open			Shielded · Sealed					
		Open Z,ZZ RU,2RU	RS,2RS	Open	D_s	dh	R	D_{s1}	dh_1	R_1			
											Min	Max	Max
10.0	3.00	130 000	-	150 000	1.6	2.4	0.05	-	-	-	-	0.03	681
14.0	4.00	120 000	-	140 000	1.8	3.2	0.1	-	-	-	-	0.1	691
11.0	3.00	120 000	-	140 000	2.3	3.2	0.1	2.3	-	3.2	0.1	0.1	68/1.5
19.0	6.00	110 000	-	130 000	2.7	3.8	0.15	2.7	-	3.8	0.15	0.1	69/1.5
19.0	6.00	97 000	-	110 000	2.8	4.4	0.1	2.8	-	4.4	0.1	0.1	682
34.0	10.0	86 000	-	100 000	3.2	4.8	0.15	2.8	-	5.2	0.1	0.2	692
40.0	13.0	69 000	-	82 000	3.2	5.8	0.15	3.2	-	5.8	0.15	0.5	602
19.0	6.00	73 000	-	86 000	3.3	5.2	0.1	3.3	-	5.2	0.1	0.2	68/2.5
32.0	11.0	67 000	-	79 000	3.7	5.8	0.15	3.7	-	5.8	0.15	0.4	69/2.5
32.0	11.0	69 000	-	81 000	4.2	5.8	0.1	3.9	3.9	5.8	0.1	0.3	683
56.0	17.0	67 000	-	79 000	4.2	6.8	0.15	4.2	3.9	6.8	0.15	0.6	693
44.0	16.0	63 000	-	74 000	4.2	7.8	0.15	4.2	-	7.8	0.15	0.9	603
65.0	23.0	56 000	32 000	67 000	4.2	8.8	0.15	4.2	4.4	8.8	0.15	1.6	623
135.0	50.0	47 000	-	57 000	5	11	0.2	5	5.9	11	0.2	3.0	633
65.0	23.0	61 000	-	72 000	5.2	7.8	0.1	5.2	4.4	7.8	0.1	0.6	684
98.0	28.5	56 000	-	67 000	5.2	9.8	0.15	5.2	-	9.8	0.15	1.8	694
99.0	37.0	55 000	-	65 000	5.6	10.4	0.2	5.6	-	10.4	0.2	2.1	604
135.0	50.0	47 000	25 000	57 000	5.6	11.4	0.2	5.6	5.9	11.4	0.2	2.9	624
195.0	71.0	43 000	-	51 000	6	14	0.3	6	-	14	0.3	5.3	634
99.0	37.0	55 000	-	65 000	6.2	9.8	0.15	6.2	-	9.8	0.15	1.0	685
135.0	50.0	52 000	-	61 000	6.6	11.4	0.2	6.6	-	11.4	0.2	2.2	695
135.0	50.0	52 000	27 000	61 000	6.6	12.4	0.2	5.9	5.9	12.4	0.2	3.5	605
195.0	71.0	43 000	-	51 000	7	14	0.3	7	-	14	0.3	5.0	625
265.0	105.0	37 000	19 000	45 000	7	17	0.3	7	8.7	17	0.3	8.5	635
110.0	45.0	50 000	-	59 000	7.2	11.8	0.15	7.2	-	11.8	0.15	1.8	686
120.0	52.0	47 000	24 000	56 000	7.6	13.4	0.2	7.6	-	13.4	0.2	3.9	696
200.0	75.0	45 000	22 000	53 000	8	15	0.3	8	-	15	0.3	5.8	606
265.0	105.0	37 000	20 000	45 000	8	17	0.3	8	8.7	17	0.3	8.1	626
335.0	140.0	33 000	17 000	39 000	8	20	0.3	8	-	20	0.3	13	636
120.0	52.0	47 000	-	56 000	8.2	12.8	0.15	8.2	-	12.8	0.15	2.0	687
165.0	72.0	44 000	23 000	51 000	9	15	0.3	9	-	15	0.3	5.3	697
265.0	105.0	41 000	22 000	48 000	9	17	0.3	8.7	8.7	17	0.3	7.6	607
335.0	140.0	33 000	18 000	39 000	9	20	0.3	9	11	20	0.3	13	627
460.0	200.0	28 000	15 000	33 000	9	24	0.3	9	-	24	0.3	24	637
165.0	72.0	44 000	-	51 000	9.6	14.4	0.2	9.6	-	14.4	0.2	3.2	688
230.0	93.0	40 000	22 000	47 000	10	17	0.3	9.4	9.4	17	0.3	7.2	698
335.0	140.0	36 000	19 000	42 000	10	20	0.3	10	11	20	0.3	12	608
340.0	145.0	30 000	18 000	36 000	10	22	0.3	10	11.8	22	0.3	18	628
460.0	200.0	28 000	16 000	33 000	10	26	0.3	10	-	26	0.3	29	638
135.0	67.0	40 000	-	47 000	10.6	15.4	0.2	10.6	-	15.4	0.2	3.5	689
250.0	110.0	37 000	21 000	43 000	11	18	0.3	11	-	18	0.3	7.5	699
340.0	145.0	34 000	19 000	41 000	11	22	0.3	11	11.6	22	0.3	15	609
460.0	200.0	29 000	17 000	34 000	13	22	0.3	12.1	12.1	22	0.3	20	629
610.0	270.0	25 000	15 000	30 000	13	26	0.6	13	-	26	0.6	35	639

Single-row deep groove ball bearing Bore diameter 10~20mm

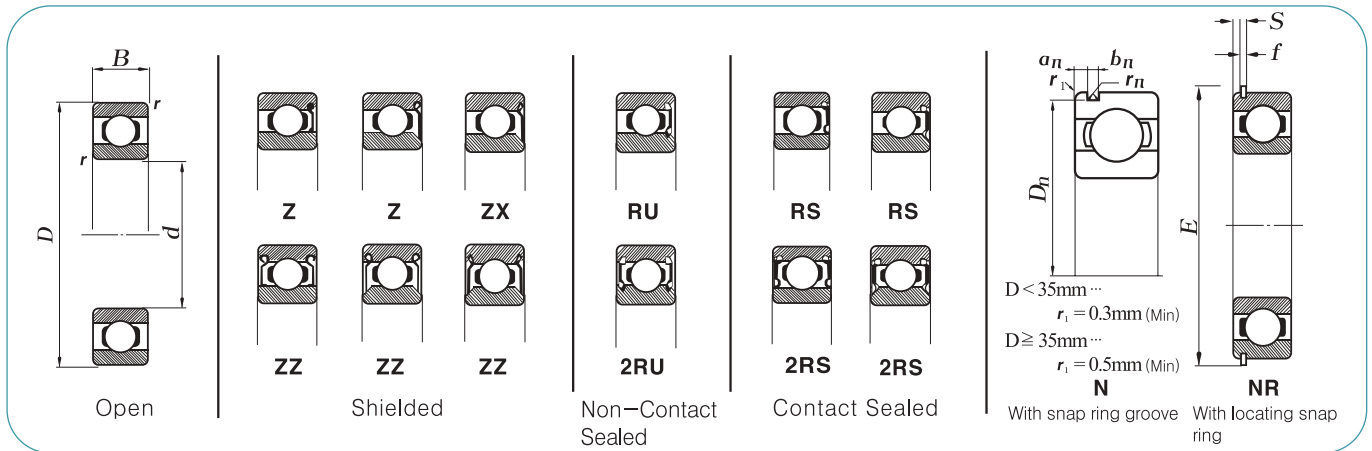

Boundary Dimensions(mm)				Bearing No.										Basic Load Ratings(kgf)		Limiting Speeds(rpm)		
d	D	B	r _s ¹⁾ Min	Open	Shielded		Non-Contact Sealed		Contact Sealed		with snap ring groove	with snap ring	Dynamic C _e	Static C _o	Grease lub		Oil lub	
					Z	ZZ	RU	2RU	RS	2RS					Open Z,ZZ RU,2RU	RS, 2RS	Open Z	
10	19	5	0.3	6800	-	-	-	-	-	-	-	-	175	86.0	37 000	-	43 000	
10	22	6	0.3	6900	-	-	-	-	-	-	-	-	275	130	34 000	-	41 000	
10	26	8	0.3	6000	... Z	... ZZ	... RU	... 2RU	... RS	... 2RS	-	-	465	200	31 000	18 000	36 000	
10	30	9	0.6	6200	... Z	... ZZ	... RU	... 2RU	... RS	... 2RS	... N	... NR	520	245	24 000	15 000	29 000	
10	35	11	0.6	6300	... Z	... ZZ	... RU	... 2RU	... RS	... 2RS	... N	... NR	825	350	22 000	13 000	27 000	
12	21	5	0.3	6801	-	-	-	-	-	-	-	-	195	105	33 000	-	39 000	
12	24	6	0.3	6901	-	-	-	-	-	-	-	-	295	150	31 000	-	36 000	
12	28	7	0.3	16001	-	-	-	-	-	-	-	-	520	245	27 000	-	32 000	
12	28	8	0.3	6001	... Z	... ZZ	... RU	... 2RU	... RS	... 2RS	-	-	520	245	27 000	16 000	32 000	
12	32	10	0.6	6201	... Z	... ZZ	... RU	... 2RU	... RS	... 2RS	... N	... NR	690	310	22 000	13 000	27 000	
12	37	12	1	6301	... Z	... ZZ	... RU	... 2RU	... RS	... 2RS	... N	... NR	990	425	20 000	12 000	25 000	
15	24	5	0.3	6802	-	-	-	-	-	-	-	-	210	130	28 000	-	33 000	
15	28	7	0.3	6902	-	-	-	-	-	-	-	-	440	230	26 000	-	30 000	
15	32	8	0.3	16002	-	-	-	-	-	-	-	-	570	290	23 000	-	28 000	
15	32	9	0.3	6002	... Z	... ZZ	... RU	... 2RU	... RS	... 2RS	-	-	570	290	23 000	14 000	27 000	
15	35	11	0.6	6202	... Z	... ZZ	... RU	... 2RU	... RS	... 2RS	... N	... NR	780	380	20 000	12 000	24 000	
15	42	13	1	6302	... Z	... ZZ	... RU	... 2RU	... RS	... 2RS	... N	... NR	1 160	555	17 000	10 000	20 000	
17	26	5	0.3	6803	-	-	-	-	-	-	-	-	265	160	26 000	-	30 000	
17	30	7	0.3	6903	-	-	-	-	-	-	-	-	470	260	23 000	-	28 000	
17	35	8	0.3	16003	-	-	-	-	-	-	-	-	610	335	21 000	-	25 000	
17	35	10	0.3	6003	... Z	... ZZ	... RU	... 2RU	... RS	... 2RS	-	-	610	335	21 000	12 000	25 000	
17	40	12	0.6	6203	... Z	... ZZ	... RU	... 2RU	... RS	... 2RS	... N	... NR	975	490	17 000	10 000	21 000	
17	47	14	1	6303	... Z	... ZZ	... RU	... 2RU	... RS	... 2RS	... N	... NR	1 390	675	15 000	9 100	18 000	
17	47	14	1	6303R	-	-	-	-	-	-	... N	... NR	1 590	775	15 000	-	18 000	
17	62	17	1.1	6403	-	-	-	-	-	-	-	-	2 110	1 000	13 000	-	15 000	
20	32	7	0.3	6804	-	-	-	-	-	-	-	-	410	250	21 000	-	23 000	
20	37	9	0.3	6904	-	-	-	-	-	-	-	-	650	375	19 000	-	23 000	
20	42	8	0.3	16004	-	-	-	-	-	-	-	-	810	455	17 000	-	21 000	
20	42	12	0.6	6004	... Z	... ZZ	... RU	... 2RU	... RS	... 2RS	... N	... NR	955	515	17 000	10 000	21 000	
20	42	12	0.6	6004R	-	-	-	-	-	-	... N	... NR	1 170	595	18 000	-	21 000	
20	47	14	1	6204	... Z	... ZZ	... RU	... 2RU	... RS	... 2RS	... N	... NR	1 310	680	15 000	8 700	17 000	
20	47	14	1	6204R	-	-	-	-	-	-	... N	... NR	1 590	775	15 000	-	18 000	
20	52	15	1.1	6304	... Z	... ZZ	... RU	... 2RU	... RS	... 2RS	... N	... NR	1 620	800	14 000	8 300	17 000	
20	52	15	1.1	6304R	-	-	-	-	-	-	... N	... NR	1 804	910	14 000	-	16 000	
20	72	19	1.1	6404	-	-	-	-	-	-	-	-	6 160	1 550	11 000	-	13 000	

Remarks 1) Minimally required measurement of Chamfer.

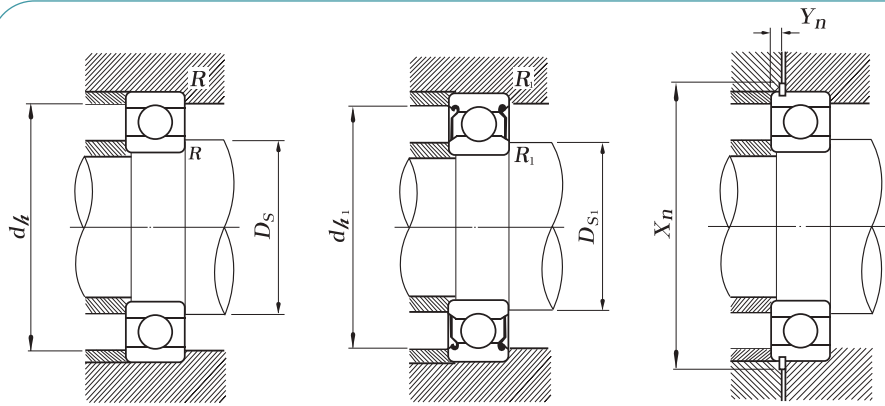

Dynamic equivalent radial load
 $P = XFr + YFa$

$\frac{F_a}{C_0}$	e	$\frac{F_a}{F_r} \leq e$		$\frac{F_a}{F_r} > e$	
		X	Y	X	Y
0.014	0.19	1	0	0.56	2.30
0.028	0.22				1.99
0.056	0.26				1.71
0.084	0.28				1.55
0.11	0.30				1.45
0.17	0.34				1.31
0.28	0.38				1.15
0.42	0.42				1.04
0.56	0.44				1.00

Static equivalent radial load

$$P_0 = 0.6Fr + 0.5Fa$$

If $P_0 < Fr$, $P_0 = Fr$

Snap ring and groove dimension(mm)									Ref. Mounting dimension(mm)						Ref. weight (kg)	Bearing No.	
Dn	an	bn	rn	S	E	f	Xn	Yn	Open			Shielded · Sealed					
									Ds	dh	R	Ds1	dh1	R1			
Max	Max	±0.15	Max	Max	Max	±0.5	Ref.	Max	Max	Max	Min	Max	Max	Max			
-	-	-	-	-	-	-	-	-	12.5	16.5	0.3	-	-	-	-	0.005	6800
-	-	-	-	-	-	-	-	-	12.5	19.5	0.3	-	-	-	-	0.010	6900
-	-	-	-	-	-	-	-	-	12.5	23.5	0.3	12.5	13	23.5	0.3	0.019	6000
28.17	2.06	1.5	0.4	3.18	34.7	1.07	35.5	2.92	15	25	0.6	15	15	25	0.6	0.032	6200
33.17	2.06	1.5	0.4	3.18	39.7	1.07	40.5	2.92	15	30	0.6	15	15	30	0.6	0.053	6300
-	-	-	-	-	-	-	-	-	14.5	18.5	0.3	-	-	-	-	0.006	6801
-	-	-	-	-	-	-	-	-	14.5	21.5	0.3	-	-	-	-	0.011	6901
-	-	-	-	-	-	-	-	-	14.5	25.5	0.3	-	-	-	-	0.024	16001
-	-	-	-	-	-	-	-	-	14.5	25.5	0.3	14.5	14.5	25.5	0.3	0.022	6001
30.15	2.06	1.5	0.4	3.18	36.7	1.07	37.5	2.92	17	27	0.6	16	16	27	0.6	0.037	6201
34.77	2.06	1.5	0.4	3.18	41.3	1.07	42	2.92	18	31	1	17	17	31	1	0.060	6301
-	-	-	-	-	-	-	-	-	17.5	21.5	0.3	-	-	-	-	0.007	6802
-	-	-	-	-	-	-	-	-	17.5	25.5	0.3	-	-	-	-	0.017	6902
-	-	-	-	-	-	-	-	-	17.5	29.5	0.3	-	-	-	-	0.025	16002
-	-	-	-	-	-	-	-	-	17.5	29.5	0.3	17.5	19	29.5	0.3	0.030	6002
33.17	2.06	1.5	0.4	3.18	39.7	1.07	40.5	2.92	20	30	0.6	19.5	19.5	30	0.6	0.045	6202
39.75	2.06	1.5	0.4	3.18	46.3	1.07	47	2.92	21	36	1	21	21.5	36	1	0.082	6302
-	-	-	-	-	-	-	-	-	19.5	23.5	0.3	-	-	-	-	0.008	6803
-	-	-	-	-	-	-	-	-	19.5	27.5	0.3	-	-	-	-	0.018	6903
-	-	-	-	-	-	-	-	-	19.5	32.5	0.3	-	-	-	-	0.032	16003
-	-	-	-	-	-	-	-	-	19.5	32.5	0.3	19.5	21	32.5	0.3	0.039	6003
38.1	2.06	1.5	0.4	3.18	44.6	1.07	45.5	2.92	22	35	0.6	22	22	35	0.6	0.065	6203
44.6	2.46	1.5	0.4	3.58	52.7	1.07	53.5	3.33	23	41	1	23	24.5	41	1	0.115	6303
44.6	2.46	1.5	0.4	3.58	52.7	1.07	53.5	3.33	23	41	1	-	-	-	-	0.121	6303R
-	-	-	-	-	-	-	-	-	24	55	1	-	-	-	-	0.270	6403
-	-	-	-	-	-	-	-	-	22.5	29.5	0.3	-	-	-	-	0.018	6804
-	-	-	-	-	-	-	-	-	22.5	34.5	0.3	-	-	-	-	0.036	6904
-	-	-	-	-	-	-	-	-	22.5	39.5	0.3	-	-	-	-	0.050	16004
39.75	2.06	1.5	0.4	3.18	46.3	1.07	47	2.92	25	37	0.6	23.5	23.5	37	0.6	0.069	6004
39.75	2.06	1.5	0.4	3.18	46.3	1.07	47	2.92	25	37	0.6	-	-	-	-	0.073	6004R
44.6	2.46	1.5	0.4	3.58	52.7	1.07	53.5	3.33	26	41	1	26	26	41	1	0.106	6204
44.6	2.46	1.5	0.4	3.58	52.7	1.07	53.5	3.33	26	41	1	-	-	-	-	0.114	6204R
49.73	2.46	1.5	0.4	3.58	57.9	1.07	58.5	3.33	27	45	1	26.5	26.5	45	1	0.144	6304
49.73	2.46	1.5	0.4	3.58	57.9	1.07	58.5	3.33	27	45	1	-	-	-	-	0.151	6304R
-	-	-	-	-	-	-	-	-	27	65	1	-	-	-	-	0.400	6404

Single-row deep groove ball bearing Bore diameter 22~35mm

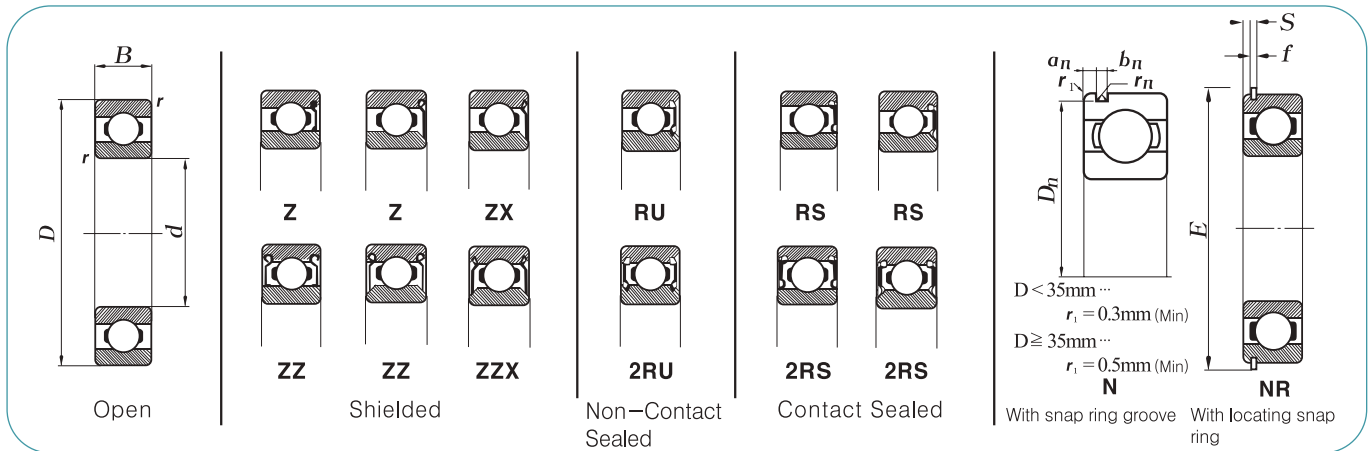

Boundary Dimensions ¹⁾				Bearing No.									Basic Load Ratings(kgf)		Limiting Speeds(rpm)		
d	D	B	r _s ¹⁾ Min	Open	Shielded		Non-Contact Sealed		Contact Sealed		snap ring groove	with snap ring	Dynamic C _e	Static C _o	Grease lub		Oil lub
					Z	ZZ	RU	2RU	RS	2RS					Open Z,ZZ RU,2RU	RS, 2RS	Open Z
22	44	12	0.6	60/22	... Z	... ZZ	... RU	... 2RU	... RS	... 2RS	... N	... NR	960	525	17 000	10 000	20 000
22	50	14	1	62/22	... Z	... ZZ	... RU	... 2RU	... RS	... 2RS	... N	... NR	1 310	680	15 000	8 700	17 000
22	56	16	1.1	63/22	... Z	... ZZ	... RU	... 2RU	... RS	... 2RS	... N	... NR	1 890	955	13 000	7 500	15 000
25	37	7	0.3	6805	-	-	-	-	-	-	-	-	440	300	18 000	-	21 000
25	42	9	0.3	6905	-	-	-	-	-	-	-	-	715	465	16 000	-	19 000
25	47	8	0.3	16005	-	-	-	-	-	-	-	-	905	570	15 000	-	18 000
25	47	12	0.6	6005	... Z	... ZZ	... RU	... 2RU	... RS	... 2RS	... N	... NR	1 030	595	15 000	9 300	18 000
25	52	15	1	6205	... Z	... ZZ	... RU	... 2RU	... RS	... 2RS	... N	... NR	1 430	800	13 000	7 700	15 000
25	52	15	1	6205R	-	-	-	-	-	-	-	... NR	1 800	950	13 000	-	16 000
25	62	17	1.1	6305	... Z	... ZZ	... RU	... 2RU	... RS	... 2RS	... N	... NR	2 100	1 150	11 000	6 700	13 000
25	62	17	1.1	6305R	-	-	-	-	-	-	... N	... NR	2 670	1 370	11 000	-	14 000
25	80	21	1.5	6405	-	-	-	-	-	-	-	-	3 680	1 980	9 100	-	11 000
28	52	12	0.6	60/28	... Z	... ZZ	... RU	... 2RU	... RS	... 2RS	... N	... NR	1 270	750	14 000	8 300	16 000
28	58	16	1	62/28	... Z	... ZZ	... RU	... 2RU	... RS	... 2RS	... N	... NR	1 830	995	12 000	7 000	14 000
28	68	18	1.1	63/28	... Z	... ZZ	... RU	... 2RU	... RS	... 2RS	... N	... NR	2 400	1 330	10 000	6 200	12 000
30	42	7	0.3	6806	-	-	-	-	-	-	-	-	460	350	15 000	-	18 000
30	47	9	0.3	6906	-	-	-	-	-	-	-	-	735	510	14 000	-	17 000
30	55	9	0.3	16006	-	-	-	-	-	-	-	-	1 150	750	13 000	-	15 000
30	55	13	1	6006	... Z	... ZZ	... RU	... 2RU	... RS	... 2RS	... N	... NR	1 350	840	13 000	7 800	15 000
30	62	16	1	6206	... Z	... ZZ	... RU	... 2RU	... RS	... 2RS	... N	... NR	1 980	1 150	11 000	6 400	13 000
30	62	16	1	6206R	-	-	-	-	-	-	... N	... NR	2 380	1 310	11 000	-	13 000
30	72	19	1.1	6306	... Z	... ZZ	... RU	... 2RU	... RS	... 2RS	... N	... NR	2 720	1 530	9 600	5 800	12 000
30	72	19	1.1	6306R	-	-	-	-	-	-	... N	... NR	3 400	1 800	9 800	-	12 000
30	90	23	1.5	6406	-	-	-	-	-	-	-	-	4 420	2 440	8 100	-	9 700
32	58	13	1	60/32	... Z	... ZZ	... RU	... 2RU	... RS	... 2RS	... N	... NR	1 530	935	12 000	7 300	14 000
32	65	17	1	62/32	... Z	... ZZ	... RU	... 2RU	... RS	... 2RS	... N	... NR	2 400	1 330	10 000	6 200	12 000
32	72	20	1.1	63/32	... Z	... ZZ	... RU	... 2RU	... RS	... 2RS	... N	... NR	3 070	1 650	9 300	5 600	11 000
35	47	7	0.3	6807	-	-	-	-	-	-	-	-	485	390	13 000	-	16 000
35	55	10	0.6	6907	-	-	-	-	-	-	-	-	1 110	790	12 000	-	14 000
35	62	9	0.3	16007	-	-	-	-	-	-	-	-	1 250	905	11 000	-	13 000
35	62	14	1	6007	... Z	... ZZ	... RU	... 2RU	... RS	... 2RS	... N	... NR	1 630	1 050	11 000	6 700	13 000
35	72	17	1.1	6207	... Z	... ZZ	... RU	... 2RU	... RS	... 2RS	... N	... NR	2 620	1 570	9 200	5 500	11 000
35	72	17	1.1	6207R	-	-	-	-	-	-	... N	... NR	3 160	1 780	9 300	-	11 000
35	80	21	1.5	6307	... Z	... ZZ	... RU	... 2RU	... RS	... 2RS	... N	... NR	3 400	1 960	8 500	5 100	10 000
35	80	21	1.5	6307R	-	-	-	-	-	-	... N	... NR	4 080	2 210	8 700	-	10 000

Remarks 1) Minimally required measurement of Chamfer.

Dynamic equivalent radial load
 $P = XFr + YFa$

$\frac{Fa}{Co}$	e	$\frac{Fa}{Fr} \leq e$		$\frac{Fa}{Fr} > e$	
		X	Y	X	Y
0.014	0.19	1	0	0.56	2.30
0.028	0.22				1.99
0.056	0.26				1.71
0.084	0.28				1.55
0.11	0.30				1.45
0.17	0.34				1.31
0.28	0.38				1.15
0.42	0.42				1.04
0.56	0.44				1.00

Static equivalent radial load
 $P_0 = 0.6Fr + 0.5Fa$
 If $P_0 < Fr$, $P_0 = Fr$

Snap ring and groove dimension(mm)									Ref. Mounting dimension(mm)						Ref. weight (kg)	Bearing No.	
Dn	an	bn	rn	S	E	f	Xn	Yn	Open			Shielded · Sealed					
									Ds	dh	R	Ds1	dh1	R1			
Max	Max	±0.15	Max	Max	Max	±0.5	Ref.	Max	Max	Max	Min	Max	Max	Max			
41.75	2.06	1.5	0.4	3.18	48.3	1.07	49	2.92	27	39	0.6	26.5	26.5	39	0.6	0.073	60/22
47.6	2.46	1.5	0.4	3.58	55.7	1.07	56.5	3.33	28	44	1	27	27	44	1	0.118	62/22
53.6	2.46	1.5	0.4	3.58	61.7	1.07	62.5	3.33	29	49	1	29	30	49	1	0.201	63/22
-	-	-	-	-	-	-	-	-	27.5	34.5	0.3	-	-	-	-	0.022	6805
-	-	-	-	-	-	-	-	-	27.5	39.5	0.3	-	-	-	-	0.041	6905
-	-	-	-	-	-	-	-	-	27.5	44.5	0.3	-	-	-	-	0.060	16005
44.6	2.06	1.5	0.4	3.18	52.7	1.07	53.5	2.92	30	42	0.6	29	29	42	0.6	0.080	6005
49.73	2.46	1.5	0.4	3.58	57.9	1.07	58.5	3.33	31	46	1	31	31	46	1	0.128	6205
49.73	2.46	1.5	0.4	3.58	57.9	1.07	58.5	3.33	31	46	1	-	-	-	-	0.138	6205R
59.61	3.28	2.05	0.6	4.98	67.7	1.65	68.5	4.67	32	55	1	32	34.5	55	1	0.232	6305
59.61	3.28	2.05	0.6	4.98	67.7	1.65	68.5	4.67	32	55	1	-	-	-	-	0.255	6305R
-	-	-	-	-	-	-	-	-	33.5	71.5	1.5	-	-	-	-	0.530	6405
49.73	2.06	1.5	0.4	3.18	57.9	1.07	58.5	2.92	33	47	0.6	32.5	32.5	47	0.6	0.097	60/28
55.6	2.46	1.5	0.4	3.58	63.7	1.07	64.5	3.33	34	52	1	34	34.5	52	1	0.173	62/28
64.82	3.28	2.05	0.6	4.98	74.6	1.65	76	4.67	35	61	1	35	38	61	1	0.328	63/28
-	-	-	-	-	-	-	-	-	32.5	39.5	0.3	-	-	-	-	0.026	6806
-	-	-	-	-	-	-	-	-	32.5	44.5	0.3	-	-	-	-	0.045	6906
-	-	-	-	-	-	-	-	-	32.5	52.5	0.3	-	-	-	-	0.085	16006
52.6	2.08	1.5	0.4	3.20	60.7	1.07	61.5	2.9	36	49	1	34.5	34.5	49	1	0.116	6006
59.61	3.28	2.05	0.6	4.98	67.7	1.65	68.5	4.67	36	56	1	36	37	56	1	0.199	6206
59.61	3.28	2.05	0.6	4.98	67.7	1.65	68.5	4.67	36	56	1	-	-	-	-	0.212	6206R
68.81	3.28	2.05	0.6	4.98	78.6	1.65	80	4.67	37	65	1	37	41.5	65	1	0.346	6306
68.81	3.28	2.05	0.6	4.98	78.6	1.65	80	4.67	37	65	1	-	-	-	-	0.379	6306R
-	-	-	-	-	-	-	-	-	38.5	81.5	1.5	-	-	-	-	0.735	6406
55.6	2.08	1.5	0.4	3.20	63.7	1.07	64.5	2.9	38	52	1	36.5	36.5	52	1	0.127	60/32
62.6	3.28	2.05	0.6	4.98	70.7	1.65	71.5	4.67	38	59	1	38	38.5	59	1	0.228	62/32
71.83	3.28	2.05	0.6	4.98	81.6	1.65	83	4.67	39	68	1	39	41.5	68	1	0.437	63/32
-	-	-	-	-	-	-	-	-	37.5	44.5	0.3	-	-	-	-	0.030	6807
-	-	-	-	-	-	-	-	-	40	50	0.6	-	-	-	-	0.073	6907
-	-	-	-	-	-	-	-	-	37.5	59.5	0.3	-	-	-	-	0.110	16007
59.61	2.08	2.05	0.6	3.78	67.7	1.65	68.5	3.48	41	56	1	40.5	40.5	56	1	0.155	6007
68.81	3.28	2.05	0.6	4.98	78.6	1.65	80	4.67	42	65	1	42	44	65	1	0.288	6207
68.81	3.28	2.05	0.6	4.98	78.6	1.65	80	4.67	42	65	1	-	-	-	-	0.309	6207R
76.81	3.28	2.05	0.6	4.98	86.6	1.65	88	4.67	43.5	71.5	1.5	43.5	46.5	71.5	1.5	0.457	6607
76.81	3.28	2.05	0.6	4.98	86.6	1.65	88	4.67	43.5	71.5	1.5	-	-	-	-	0.494	6307R

Single-row deep groove ball bearing Bore diameter 35~60mm

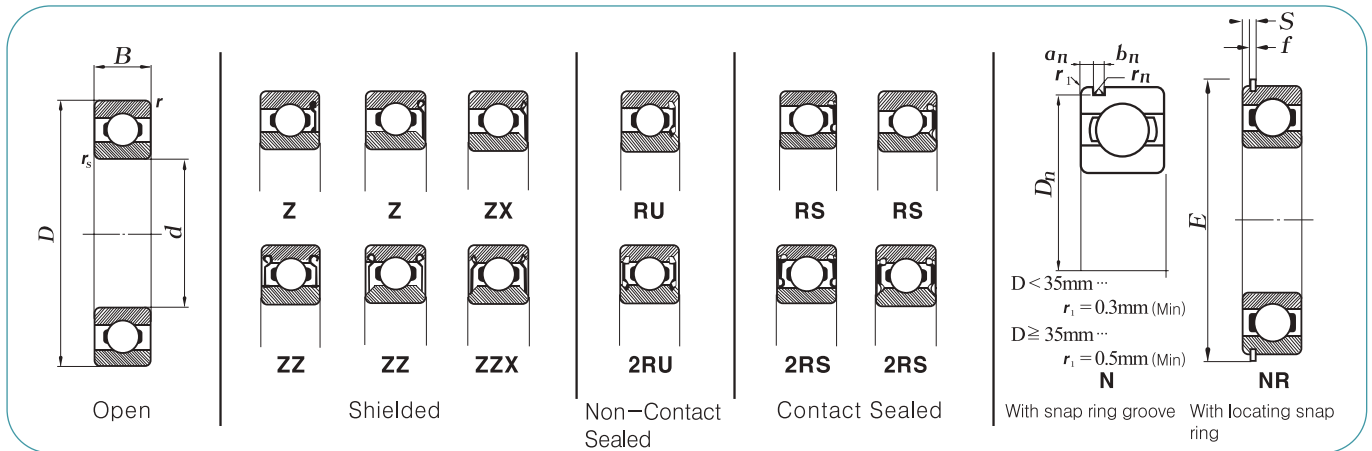

Boundary Dimensions ¹⁾				Bearing No.								Basic Load Ratings(kgf)		Limiting Speeds(rpm)			
d	D	B	rs ¹⁾ Min	Open	Shielded		Non-Contact Sealed		Contact Sealed		snap ring groove	with snap ring	Dynamic Ce	Static Co	Grease lub		Oil lub
					Z	ZZ	RU	2RU	RS	2RS					Open Z,ZZ RU,2RU	RS, 2RS	Open Z
35	100	25	1.5	6407	-	-	-	-	-	-	-	-	5 610	3 160	7 200	-	8 600
40	52	7	0.3	6808	-	-	-	-	-	-	-	-	505	425	12 000	-	14 000
40	62	12	0.6	6908	-	-	-	-	-	-	-	-	1 400	1 010	11 000	-	13 000
40	68	9	0.3	16008	-	-	-	-	-	-	-	-	1 290	985	9 800	-	12 000
40	68	15	1	6008	... Z	... ZZ	... RU	... 2RU	... RS	... 2RS	... N	... NR	1 710	1 170	10 000	6 100	12 000
40	80	18	1.1	6208	... Z	... ZZ	... RU	... 2RU	... RS	... 2RS	... N	... NR	2 970	1 820	8 300	5 000	10 000
40	90	23	1.5	6308	... Z	... ZZ	... RU	... 2RU	... RS	... 2RS	... N	... NR	4 150	2 450	7 700	4 600	9 200
40	110	27	2	6408	-	-	-	-	-	-	-	-	6 490	3 730	6 600	-	7 900
45	58	7	0.3	6809	-	-	-	-	-	-	-	-	630	550	11 000	-	13 000
45	68	12	0.6	6909	-	-	-	-	-	-	-	-	1 440	1 110	9 700	-	11 000
45	75	10	0.6	16009	-	-	-	-	-	-	-	-	1 580	1 250	8 900	-	10 000
45	75	16	1	6009	... Z	... ZZ	... RU	... 2RU	... RS	... 2RS	... N	... NR	2 140	1 540	9 200	5 500	11 000
45	85	19	1.1	6209	... Z	... ZZ	... RU	... 2RU	... RS	... 2RS	... N	... NR	3 330	2 070	7 700	4 600	9 200
45	100	25	1.5	6309	... Z	... ZZ	... RU	... 2RU	... RS	... 2RS	... N	... NR	4 980	3 010	6 800	4 100	8 100
45	120	29	2	6409	-	-	-	-	-	-	-	-	7 880	4 600	6 000	-	7 200
50	65	7	0.3	6810	-	-	-	-	-	-	-	-	670	620	9 600	-	11 000
50	72	12	0.6	6910	-	-	-	-	-	-	-	-	1 480	1 200	9 000	-	11 000
50	80	10	0.6	16010	-	-	-	-	-	-	-	-	1 630	1 350	8 200	-	9 700
50	80	16	1	6010	... Z	... ZZ	... RU	... 2RU	... RS	... 2RS	... N	... NR	2 220	1 690	8 400	5 000	9 900
50	90	20	1.1	6210	... Z	... ZZ	... RU	... 2RU	... RS	... 2RS	... N	... NR	3 580	2 370	7 100	4 200	8 500
50	90	20	1.1	6210R	-	-	-	-	-	-	... N	... NR	4 120	2 600	7 100	-	8 600
50	110	27	2	6310	... Z	... ZZ	... RU	... 2RU	... RS	... 2RS	... N	... NR	6 320	3 900	6 100	3 600	7 300
50	130	31	2.1	6410	-	-	-	-	-	-	-	-	8 460	5 040	5 500	-	6 000
55	72	9	0.3	6811	-	-	-	-	-	-	-	-	895	825	8 700	-	10 000
55	80	13	1	6911	-	-	-	-	-	-	-	-	1 690	1 440	8 100	-	9 600
55	90	11	0.6	16011	-	-	-	-	-	-	-	-	1 970	1 670	7 400	-	8 800
55	90	18	1.1	6011	... Z	... ZZ	... RU	... 2RU	... RS	... 2RS	... N	... NR	2 880	2 170	7 600	4 500	8 900
55	100	21	1.5	6211	... Z	... ZZ	... RU	... 2RU	... RS	... 2RS	... N	... NR	4 420	3 000	6 300	3 800	7 600
55	120	29	2	6311	... Z	... ZZ	... RU	... 2RU	... RS	... 2RS	... N	... NR	7 300	4 580	5 600	3 300	6 700
55	140	33	2.1	6411	-	-	-	-	-	-	-	-	10 200	6 350	5 000	-	6 000
60	78	10	0.3	6812	-	-	-	-	-	-	-	-	1 170	1 080	8 000	-	9 400
60	85	13	1	6912	-	-	-	-	-	-	-	-	2 060	1 770	7 500	-	8 900
60	95	11	0.6	16012	-	-	-	-	-	-	-	-	2 020	1 790	6 900	-	8 100
60	95	18	1.1	6012	... Z	... ZZ	... RU	... 2RU	... RS	... 2RS	... N	... NR	3 000	2 370	7 100	4 200	8 400
60	110	22	1.5	6212	... Z	... ZZ	... RU	... 2RU	... RS	... 2RS	... N	... NR	5 350	3 690	5 700	3 400	6 900

Remarks 1) Minimally required measurement of Chamfer.

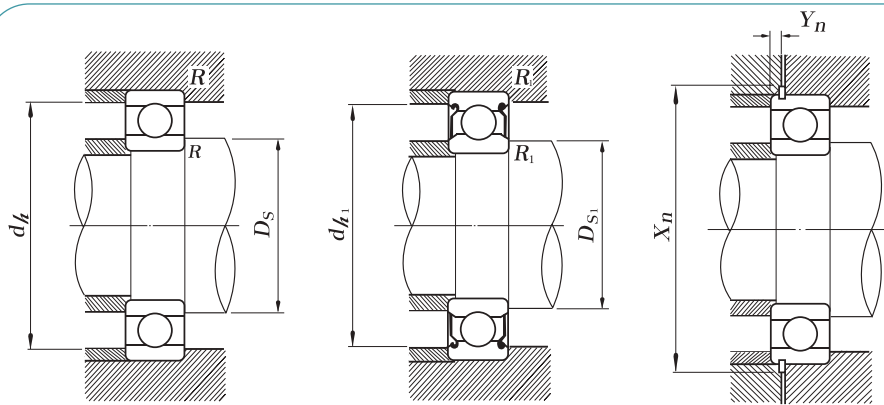

Dynamic equivalent radial load
 $P = XFr + YFa$

$\frac{F_a}{C_o}$	e	$\frac{F_a}{F_r} \leq e$		$\frac{F_a}{F_r} > e$	
		X	Y	X	Y
0.014	0.19	1	0	0.56	2.30
0.028	0.22				1.99
0.056	0.26				1.71
0.084	0.28				1.55
0.11	0.30				1.45
0.17	0.34				1.31
0.28	0.38				1.15
0.42	0.42				1.04
0.56	0.44				1.00

Static equivalent radial load

$$P_o = 0.6Fr + 0.5Fa$$

If $P_o < Fr$, $P_o = Fr$

Snap ring and groove dimension(mm)									Ref. Mounting dimension(mm)						Ref. weight (kg)	Bearing No.	
Dn	an	bn	rn	S	E	f	Xn	Yn	Open			Shielded · Sealed					
									Ds	dh	R	Ds1	dh1	R1			
Max	Max	±0.15	Max	Max	Max	±0.5	Ref.	Max	Max	Max	Min	Max	Max	Max			
-	-	-	-	-	-	-	-	-	43.5	91.5	1.5	-	-	-	-	0.952	6407
-	-	-	-	-	-	-	-	-	42.5	49.5	0.3	-	-	-	-	0.033	6808
-	-	-	-	-	-	-	-	-	45	57	0.6	-	-	-	-	0.11	6908
-	-	-	-	-	-	-	-	-	42.5	65.5	0.3	-	-	-	-	0.125	16008
64.82	2.49	2.05	0.6	4.19	74.6	1.65	76	3.89	46	62	1	45.5	45.5	62	1	0.192	6008
76.81	3.28	2.05	0.6	4.98	86.6	1.65	88	4.67	47	73	1	47	49.5	73	1	0.366	6208
86.79	3.28	2.85	0.6	5.74	96.5	2.41	98	5.43	45.8	81.5	1.5	48.5	52.5	81.5	1.5	0.633	6308
-	-	-	-	-	-	-	-	-	50	100	2	-	-	-	-	1.23	6408
-	-	-	-	-	-	-	-	-	47.5	55.5	0.3	-	-	-	-	0.040	6809
-	-	-	-	-	-	-	-	-	50	63	0.6	-	-	-	-	0.12	6909
-	-	-	-	-	-	-	-	-	50	70	0.6	-	-	-	-	0.170	16009
71.83	2.49	2.05	0.6	4.19	81.6	1.65	83	3.89	51	69	1	50.5	50.5	69	1	0.245	6009
81.81	3.28	2.05	0.6	4.98	91.6	1.65	93	4.67	52	78	1	52	54.0	78	1	0.407	6209
96.8	3.28	2.85	0.6	5.74	106.5	2.41	108	5.43	53.5	91.5	1.5	53.5	59	91.5	1.5	0.833	6309
-	-	-	-	-	-	-	-	-	55	110	2	-	-	-	-	1.53	6409
-	-	-	-	-	-	-	-	-	52.5	62.5	0.3	-	-	-	-	0.052	6810
-	-	-	-	-	-	-	-	-	55	67	0.6	-	-	-	-	0.13	6910
-	-	-	-	-	-	-	-	-	55	75	0.6	-	-	-	-	0.180	16010
76.81	2.49	2.05	0.6	4.19	86.6	1.65	88	3.89	56	74	1	56	56	74	1	0.261	6010
86.79	3.28	2.85	0.6	5.74	96.5	2.41	98	5.43	57	83	1	57	59.5	83	1	0.463	6210
86.79	3.28	2.85	0.6	5.74	96.5	2.41	98	5.43	57	83	1	-	-	-	-	0.487	6210R
106.81	3.28	2.85	0.6	5.74	116.6	2.41	118	5.43	60	100	2	60	66	100	2	1.07	6310
-	-	-	-	-	-	-	-	-	62	118	2	-	-	-	-	1.88	6410
-	-	-	-	-	-	-	-	-	57.5	69.5	0.3	-	-	-	-	0.083	6811
-	-	-	-	-	-	-	-	-	61	74	1	-	-	-	-	0.18	6911
-	-	-	-	-	-	-	-	-	60	85	0.6	-	-	-	-	0.260	16011
86.79	2.87	2.85	0.6	5.33	96.5	2.41	98	5.03	62	83	1	62	62	83	1	0.385	6011
96.8	3.28	2.85	0.6	5.74	106.5	2.41	108	5.43	63.5	91.5	1.5	63.5	66	91.5	1.5	0.607	6211
115.21	4.06	3.25	0.6	6.88	129.7	2.77	131.5	6.58	65	110	2	65	72	110	2	1.37	6311
-	-	-	-	-	-	-	-	-	67	128	2	-	-	-	-	2.29	6411
-	-	-	-	-	-	-	-	-	62.5	75.5	0.3	-	-	-	-	0.104	6812
-	-	-	-	-	-	-	-	-	66	79	1	-	-	-	-	0.19	6912
-	-	-	-	-	-	-	-	-	65	90	0.6	-	-	-	-	0.280	16012
91.82	2.87	2.85	0.6	5.33	101.6	2.41	103	5.03	67	88	1	66.5	66.5	88	1	0.415	6012
106.81	3.28	2.85	0.6	5.74	116.6	2.41	118	5.43	68.5	101.5	1.5	68.5	73	101.5	1.5	0.783	6212

Single-row deep groove ball bearing Bore diameter 60~85mm

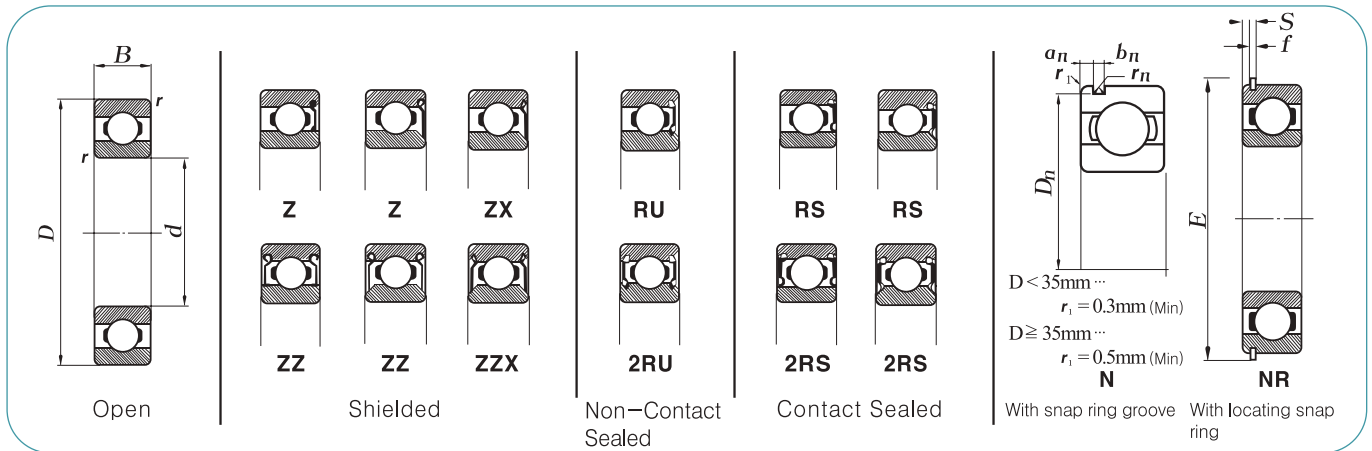

Boundary Dimensions ⁽¹⁾				Bearing No.									Basic Load Ratings(kgf)		Limiting Speeds(rpm)		
d	D	B	r _s ¹⁾ Min	Open	Shielded		Non-Contact Sealed		Contact Sealed		snap ring groove	with snap ring	Dynamic C _e	Static C _o	Grease lub		Oil lub
					Z	ZZ	RU	2RU	RS	2RS					Open Z,ZZ RU,2RU	RS, 2RS	Open Z
60	130	31	2.1	6312	... Z	... ZZ	... RU	... 2RU	... RS	... 2RS	... N	... NR	8 350	5 320	5 200	3 100	6 200
60	150	35	2.1	6412	-	-	-	-	-	-	-	-	11 200	7 220	4 600	-	5 500
65	85	10	0.6	6813	-	-	-	-	-	-	-	-	1 220	1 170	7 300	-	8 600
65	90	13	1	6913	-	-	-	-	-	-	-	-	1 770	1 640	7 100	-	8 400
65	100	11	0.6	16013	-	-	-	-	-	-	-	-	1 750	1 630	6 600	-	7 800
65	100	18	1.1	6013	... Z	... ZZ	... RU	... 2RU	... RS	... 2RS	... N	... NR	3 110	2 570	6 600	4 000	7 800
65	120	23	1.5	6213	... Z	... ZZ	... RU	... 2RU	... RS	... 2RS	... N	... NR	5 840	4 090	5 400	3 200	6 400
65	140	33	2.1	6313	... Z	... ZZ	... RU	... 2RU	... RS	... 2RS	... N	... NR	9 450	6 110	4 800	2 900	5 800
65	160	37	2.1	6413	-	-	-	-	-	-	-	-	12 100	8 070	4 300	-	5 200
70	90	10	0.6	6814	-	-	-	-	-	-	-	-	1 230	1 220	6 800	-	8 100
70	100	16	1	6914	-	-	-	-	-	-	-	-	2 420	2 160	6 400	-	7 600
70	110	13	0.6	16014	-	-	-	-	-	-	-	-	3 070	2 610	6 100	-	7 200
70	110	20	1.1	6014	... Z	... ZZ	... RU	... 2RU	... RS	... 2RS	... N	... NR	3 880	3 160	6 100	3 600	7 200
70	125	24	1.5	6214	... Z	... ZZ	... RU	... 2RU	... RS	... 2RS	... N	... NR	6 340	4 490	5 100	3 100	6 100
70	150	35	2.1	6314	... Z	... ZZ	... RU	... 2RU	... RS	... 2RS	... N	... NR	10 600	6 960	4 500	2 700	5 400
70	180	42	3	6414	-	-	-	-	-	-	-	-	14 700	10 600	3 900	-	4 600
75	95	10	0.6	6815	-	-	-	-	-	-	-	-	1 280	1 310	6 400	-	7 600
75	105	16	1	6915	-	-	-	-	-	-	-	-	2 480	2 300	6 100	-	7 200
75	115	13	0.6	16015	-	-	-	-	-	-	-	-	2 810	2 580	5 700	-	6 700
75	115	20	1.1	6015	... Z	... ZZ	... RU	... 2RU	... RS	... 2RS	... N	... NR	4 030	3 420	5 700	3 400	6 800
75	130	25	1.5	6215	... Z	... ZZ	... RU	... 2RU	... RS	... 2RS	... N	... NR	6 880	4 920	4 800	2 900	5 800
75	160	37	2.1	6315	... ZX	... ZZX	... RU	... 2RU	... RS	... 2RS	... N	... NR	11 600	7 870	4 200	2 500	5 000
75	190	45	3	6415	-	-	-	-	-	-	-	-	15 700	11 700	3 600	-	4 400
80	100	10	0.6	6816	-	-	-	-	-	-	-	-	1 290	1 360	6 100	-	7 200
80	110	16	1	6916	-	-	-	-	-	-	-	-	2 550	2 450	5 700	-	6 800
80	125	14	0.6	16016	-	-	-	-	-	-	-	-	3 240	3 030	5 200	-	6 100
80	125	22	1.1	6016	... ZX	... ZZX	... RU	... 2RU	... RS	... 2RS	... N	... NR	4 860	4 060	5 300	3 200	6 300
80	140	26	2	6216	... Z	... ZZ	... RU	... 2RU	... RS	... 2RS	... N	... NR	7 410	5 400	4 500	2 700	5 400
80	170	39	2.1	6316	... ZX	... ZZX	... RU	... 2RU	... RS	... 2RS	... N	... NR	12 500	8 840	3 900	2 400	4 700
80	200	48	3	6416	-	-	-	-	-	-	-	-	16 700	12 800	3 400	-	4 100
85	110	13	1	6817	-	-	-	-	-	-	-	-	1 910	1 940	5 600	-	6 600
85	120	18	1.1	6917	-	-	-	-	-	-	-	-	3 250	3 020	5 300	-	6 300
85	130	14	0.6	16017	-	-	-	-	-	-	-	-	3 330	3 230	4 900	-	5 800
85	130	22	1.1	6017	... ZX	... ZZX	... RU	... 2RU	... RS	... 2RS	... N	... NR	5 040	4 400	5 000	3 000	5 900
85	150	28	2	6217	... Z	... ZZ	... RU	... 2RU	... RS	... 2RS	... N	... NR	8 560	6 310	4 200	2 500	5 000

Remarks Minimally required measurement of Chamfer.

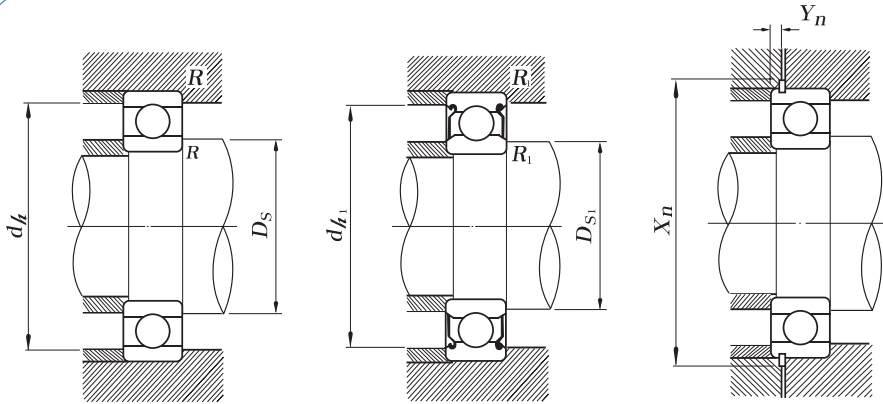

Dynamic equivalent radial load
 $P = XFr + YFa$

$\frac{Fa}{Co}$	e	$\frac{Fa}{Fr} \leq e$		$\frac{Fa}{Fr} > e$	
		X	Y	X	Y
0.014	0.19	1	0	0.56	2.30
0.028	0.22				1.99
0.056	0.26				1.71
0.084	0.28				1.55
0.11	0.30				1.45
0.17	0.34				1.31
0.28	0.38				1.15
0.42	0.42				1.04
0.56	0.44				1.00

Static equivalent radial load

$$P_0 = 0.6Fr + 0.5Fa$$

If $P_0 < Fr$, $P_0 = Fr$

Snap ring and groove dimension(mm)									Ref. Mounting dimension(mm)						Ref. weight (kg)	Bearing No.	
Dn	an	bn	rn	S	E	f	Xn	Yn	Open			Shielded · Sealed					
									Ds	dh	R	Ds1	dh1	R1			
Max	Max	±0.15	Max	Max	Max	±0.5	Ref.	Max	Max	Max	Min	Max	Max	Max			
125.22	4.06	3.25	0.6	6.88	139.7	2.77	141.5	6.58	72	118	2	72	78	118	2	1.70	6312
-	-	-	-	-	-	-	-	-	72	138	2	-	-	-	-	2.77	6412
-	-	-	-	-	-	-	-	-	70	80	0.6	-	-	-	-	0.126	6813
-	-	-	-	-	-	-	-	-	71	84	1	-	-	-	-	0.20	6913
-	-	-	-	-	-	-	-	-	70	95	0.6	-	-	-	-	0.300	16013
96.8	2.87	2.85	0.6	5.33	106.5	2.41	108	5.03	72	93	1	72	72.5	93	1	0.435	6013
115.21	4.06	3.25	0.6	6.88	129.7	2.77	131.5	6.58	73.5	111.5	1.5	73.5	78	111.5	1.5	0.990	6213
135.23	4.9	3.25	0.6	7.72	149.7	2.77	152	7.37	77	128	2	77	84	128	2	2.08	6313
-	-	-	-	-	-	-	-	-	77	148	2	-	-	-	-	3.30	6413
-	-	-	-	-	-	-	-	-	75	85	0.6	-	-	-	-	0.134	6814
-	-	-	-	-	-	-	-	-	76	94	1	-	-	-	-	0.33	6914
-	-	-	-	-	-	-	-	-	75	105	0.6	-	-	-	-	0.433	16014
106.81	2.87	2.85	0.6	5.33	116.6	2.41	118	5.03	77	103	1	77	78.5	103	1	0.602	6014
120.22	4.06	3.25	0.6	6.88	134.7	2.77	136.5	6.58	78.5	116.5	1.5	78.5	82	116.5	1.5	1.07	6214
145.24	4.9	3.25	0.6	7.72	159.7	2.77	162	7.37	82	138	2	82	89	138	2	2.52	6314
-	-	-	-	-	-	-	-	-	84	166	2.5	-	-	-	-	4.83	6414
-	-	-	-	-	-	-	-	-	80	90	0.6	-	-	-	-	0.142	6815
-	-	-	-	-	-	-	-	-	81	99	1	-	-	-	-	0.35	6915
-	-	-	-	-	-	-	-	-	80	110	0.6	-	-	-	-	0.457	16015
111.81	2.87	2.85	0.6	5.33	121.6	2.41	123	5.03	82	108	1	82	82.5	108	1	0.636	6015
125.22	4.06	3.25	0.6	6.88	139.7	2.77	141.5	6.58	83.5	121.5	1.5	83.5	86.5	121.5	1.5	1.18	6215
155.22	4.9	3.25	0.6	7.72	169.7	2.77	172	7.37	87	148	2	87	95	148	2	3.02	6315
-	-	-	-	-	-	-	-	-	89	176	2.5	-	-	-	-	8.87	6415
-	-	-	-	-	-	-	-	-	85	95	0.6	-	-	-	-	0.150	6816
-	-	-	-	-	-	-	-	-	86	104	1	-	-	-	-	0.38	6916
-	-	-	-	-	-	-	-	-	85	120	0.6	-	-	-	-	0.597	16016
120.22	2.87	3.25	0.6	5.69	134.7	2.77	136.5	5.39	87	118	1	87	88.5	118	1	0.850	6016
135.23	4.9	3.25	0.6	7.72	149.7	2.77	152	7.37	90	130	2	90	92	130	2	1.40	6216
163.65	5.69	3.65	0.6	8.79	182.9	3.05	185	8.44	92	158	2	92	102	158	2	3.59	6316
-	-	-	-	-	-	-	-	-	94	186	2.5	-	-	-	-	6.84	6416
-	-	-	-	-	-	-	-	-	91	104	1	-	-	-	-	0.266	6817
-	-	-	-	-	-	-	-	-	92	113	1	-	-	-	-	0.535	6917
-	-	-	-	-	-	-	-	-	90	125	0.6	-	-	-	-	0.626	16017
125.22	3.71	3.25	0.6	5.69	139.7	2.77	141.5	5.39	92	123	1	92	94.5	123	1	0.890	6017
145.24	4.9	3.25	0.6	7.72	159.7	2.77	162	7.37	95	140	2	95	99	140	2	1.79	6217

Single-row deep groove ball bearing Bore diameter 85~120mm

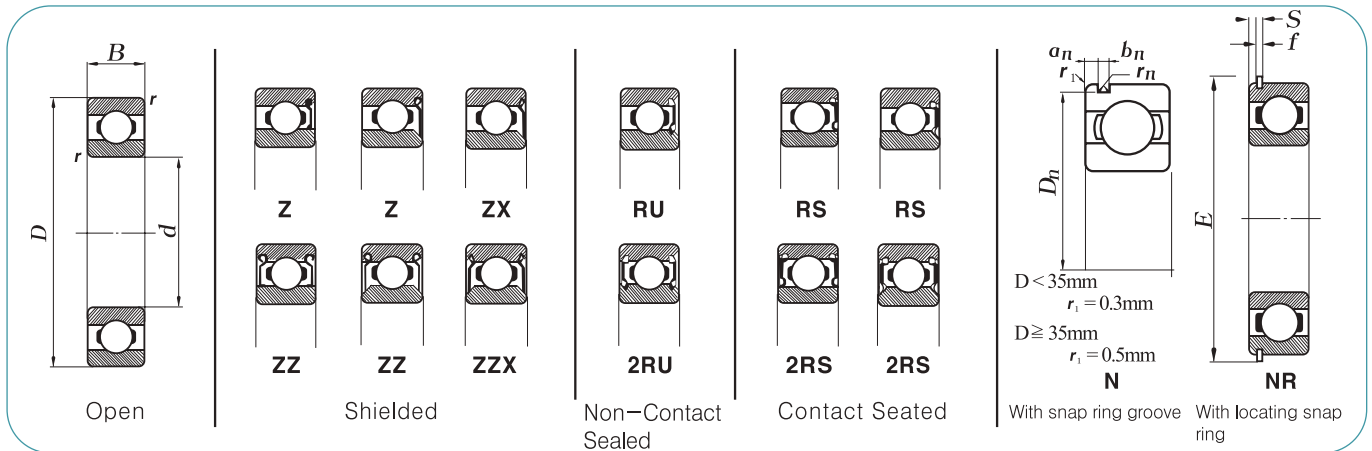

Boundary Dimensions ⁽¹⁾				Bearing No.									Basic Load Ratings(kgf)		Limiting Speeds(rpm)		
d	D	B	r _s ¹⁾ Min	Open	Shielded		Non-Contact Sealed		Contact Sealed		snap ring groove	with snap ring	Dynamic C _e	Static C _o	Grease lub		Oil lub
					Z	ZZ	RU	2RU	RS	2RS					Open Z,ZZ RU,2RU	RS, 2RS	Open Z
85	180	41	3	6317	...ZX	...ZZX	...RU	...2RU	...RS	...2RS	...N	...NR	13 500	9 870	3 700	2 200	4 400
85	210	52	4	6417	-	-	-	-	-	-	-	-	17 700	13 900	3 300	-	3 900
90	115	13	1	6818	-	-	-	-	-	-	-	-	1 940	2 010	5 300	-	6 300
90	125	18	1.1	6918	-	-	-	-	-	-	-	-	3 350	3 220	5 100	-	6 000
90	140	16	1	16018	-	-	-	-	-	-	-	-	4 070	3 770	4 700	-	5 600
90	140	24	1.5	6018	...ZX	...ZZX	...RU	...2RU	...RS	...2RS	...N	...NR	5 930	5 070	4 700	2 800	5 600
90	160	30	2	6218	...ZX	...ZZX	...RU	...2RU	...RS	...2RS	...N	...NR	9 790	7 300	3 900	2 400	4 700
90	190	43	3	6318	...ZX	...ZZX	...RU	...2RU	...RS	...2RS	...N	...NR	14 500	10 900	3 500	2 100	4 200
90	225	54	4	6418	-	-	-	-	-	-	-	-	18 800	15 200	3 100	-	3 700
95	130	18	1.1	6919	-	-	-	-	-	-	-	-	3 430	3 420	4 800	-	5 700
95	145	16	1	16019	-	-	-	-	-	-	-	-	4 200	4 030	4 500	-	5 300
95	145	24	1.5	6019	...ZX	...ZZX	...RU	...2RU	...RS	...2RS	...N	...NR	6 160	5 500	4 400	2 700	5 200
95	170	32	2.1	6219	...ZX	...ZZX	...RU	...2RU	...RS	...2RS	...N	...NR	11 100	8 350	3 700	2 200	4 400
95	200	45	3	6319	...ZX	...ZZX	...RU	...2RU	...RS	...2RS	...N	...NR	15 600	12 100	3 300	2 000	4 000
100	125	13	1	6820	-	-	-	-	-	-	-	-	1 990	2 160	4 800	-	5 700
100	140	20	1.1	6920	-	-	-	-	-	-	-	-	4 590	4 270	4 500	-	5 300
100	150	16	1	16020	-	-	-	-	-	-	-	-	4 320	4 300	4 300	-	5 100
100	150	24	1.5	6020	...ZX	...ZZX	...RU	...2RU	...RS	...2RS	...N	...NR	6 130	5 520	4 300	2 600	5 100
100	180	34	2.1	6220	...ZX	...ZZX	...RU	...2RU	...RS	...2RS	...N	...NR	12 500	9 490	3 500	2 100	4 200
100	215	47	3	6320	...ZX	...ZZX	...RU	...2RU	...RS	...2RS	-	-	17 700	14 400	3 000	1 800	3 600
105	145	20	1.1	6921	-	-	-	-	-	-	-	-	4 740	4 570	4 300	-	5 100
105	160	18	1	16021	-	-	-	-	-	-	-	-	4 270	4 300	4 100	-	4 800
105	160	26	2	6021	...ZX	...ZZX	...RU	...2RU	...RS	...2RS	...N	...NR	7 370	6 710	4 000	2 400	4 700
105	190	36	2.1	6221	...ZX	...ZZX	...RU	...2RU	...RS	...2RS	...N	...NR	13 600	10 700	3 300	2 000	3 900
105	225	49	3	6321	...ZX	...ZZX	...RU	...2RU	...RS	...2RS	-	-	18 700	15 700	2 900	1 800	3 500
110	140	16	1	6822	-	-	-	-	-	-	-	-	2 860	3 130	4 300	-	5 100
110	150	20	1.1	6922	-	-	-	-	-	-	-	-	4 880	4 870	4 100	-	4 900
110	170	19	1	16022	-	-	-	-	-	-	-	-	5 860	5 780	3 800	-	4 500
110	170	28	2	6022	...ZX	...ZZX	...RU	...2RU	...RS	...2RS	...N	...NR	8 360	7 440	3 800	2 300	4 500
110	200	38	2.1	6222	...ZX	...ZZX	...RU	...2RU	...RS	...2RS	...N	...NR	14 700	12 000	3 100	1 800	3 700
110	240	50	3	6322	...ZX	...ZZX	...RU	...2RU	...RS	...2RS	-	-	20 900	18 300	2 700	1 600	3 200
120	150	16	1	6824	-	-	-	-	-	-	-	-	2 950	3 360	4 000	-	4 700
120	165	22	1.1	6924	-	-	-	-	-	-	-	-	5 840	5 800	3 800	-	4 400
120	180	19	1	16024	-	-	-	-	-	-	-	-	6 440	6 460	3 600	-	4 200
120	180	28	2	6024	...ZX	...ZZX	...RU	...2RU	...RS	...2RS	...N	...NR	8 660	8 080	3 600	2 100	4 200

Remarks Minimally required measurement of Chamfer.

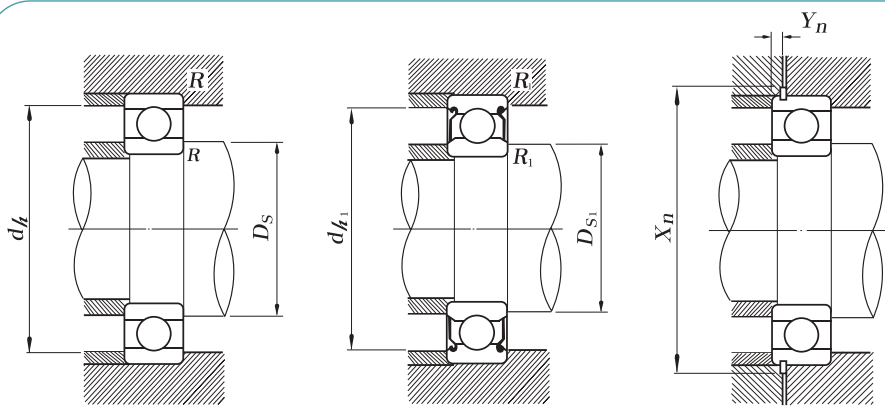

Dynamic equivalent radial load
 $P = XFr + YFa$

$\frac{F_a}{C_0}$	e	$\frac{F_a}{F_r} \leq e$		$\frac{F_a}{F_r} > e$	
		X	Y	X	Y
0.014	0.19	1	0	0.56	2.30
0.028	0.22				1.99
0.056	0.26				1.71
0.084	0.28				1.55
0.11	0.30				1.45
0.17	0.34				1.31
0.28	0.38				1.15
0.42	0.42				1.04
0.56	0.44				1.00

Static equivalent radial load

$$P_0 = 0.6Fr + 0.5Fa$$

If $P_0 < Fr$, $P_0 = Fr$

Snap ring and groove dimension(mm)									Ref. Mounting dimension(mm)						Ref. weight (kg)	Bearing No.	
Dn	an	bn	rn	S	E	f	Xn	Yn	Open			Shielded · Sealed					
									Ds	dh	R	Ds1	dh1	R1			
Max	Max	±0.15	Max	Max	Max	±0.5	Ref.	Max	Max	Max	Max	Max	Max	Max			
173.66	5.69	3.65	0.6	8.79	192.9	3.05	195	8.44	99	166	2.5	99	108	166	2.5	4.23	6317
-	-	-	-	-	-	-	-	-	103	192	3	-	-	-	-	8.07	6417
-	-	-	-	-	-	-	-	-	96	109	1	-	-	-	-	0.279	6818
-	-	-	-	-	-	-	-	-	97	118	1	-	-	-	-	0.565	6918
-	-	-	-	-	-	-	-	-	96	134	1	-	-	-	-	0.848	16018
135.23	3.71	3.25	0.6	6.53	149.7	2.77	152	6.17	98.5	131.5	1.5	98.5	100	131.5	1.5	1.16	6018
155.22	4.9	3.25	0.6	7.72	169.7	2.77	172	7.37	100	150	2	100	105	150	2	2.15	6218
183.64	5.69	3.65	0.6	8.79	202.9	3.05	205	8.44	104	176	2.5	104	114	176	2.5	4.91	6318
-	-	-	-	-	-	-	-	-	108	207	3	-	-	-	-	9.78	6418
-	-	-	-	-	-	-	-	-	102	123	1	-	-	-	-	0.705	6919
-	-	-	-	-	-	-	-	-	101	139	1	-	-	-	-	0.885	16019
140.23	3.71	3.25	0.6	6.53	154.7	2.77	157	6.17	103.5	136.5	1.5	103.5	107	136.5	1.5	1.21	6019
163.65	5.69	3.65	0.6	8.79	182.9	3.05	185	8.44	107	158	2	107	112	158	2	2.62	6219
193.65	5.69	3.65	0.6	8.79	212.9	3.05	215	8.44	109	186	2.5	109	121	186	2.5	5.67	6319
-	-	-	-	-	-	-	-	-	106	119	1	-	-	-	-	0.309	6820
-	-	-	-	-	-	-	-	-	107	133	1	-	-	-	-	0.960	6920
-	-	-	-	-	-	-	-	-	106	144	1	-	-	-	-	0.910	16020
145.24	3.71	3.25	0.6	6.53	159.7	2.77	162	6.17	108.5	141.5	1.5	108.5	109	141.5	1.5	1.25	6020
173.66	5.69	3.65	0.6	8.79	192.9	3.05	195	8.44	112	168	2	112	120	168	2	3.14	6220
-	-	-	-	-	-	-	-	-	114	201	2.5	114	130	201	2.5	7.00	6320
-	-	-	-	-	-	-	-	-	112	138	1	-	-	-	-	1.00	6921
-	-	-	-	-	-	-	-	-	111	154	1	-	-	-	-	1.20	16021
155.22	3.71	3.25	0.6	6.53	169.7	2.77	172	6.17	115	150	2	115	118	150	2	1.59	6021
183.64	5.69	3.65	0.6	8.79	202.9	3.05	205	8.44	117	178	2	117	126	178	2	3.70	6221
-	-	-	-	-	-	-	-	-	119	211	2.5	119	135	211	2.5	8.05	6321
-	-	-	-	-	-	-	-	-	116	134	1	-	-	-	-	0.606	6822
-	-	-	-	-	-	-	-	-	117	143	1	-	-	-	-	1.04	6922
-	-	-	-	-	-	-	-	-	116	164	1	-	-	-	-	1.46	16022
163.65	3.71	3.65	0.6	6.81	182.9	3.05	185	6.45	120	160	2	120	122	160	2	1.96	6022
193.65	5.69	3.65	0.6	8.79	212.9	3.05	215	8.44	122	188	2	122	133	188	2	4.36	6222
-	-	-	-	-	-	-	-	-	124	226	2.5	124	145	226	2.5	9.54	6322
-	-	-	-	-	-	-	-	-	126	144	1	-	-	-	-	0.655	6824
-	-	-	-	-	-	-	-	-	127	158	1	-	-	-	-	1.41	6924
-	-	-	-	-	-	-	-	-	126	174	1	-	-	-	-	1.80	16024
173.66	3.71	3.65	0.6	6.81	192.9	3.05	195	6.45	130	170	2	130	132	170	2	2.07	6024

Single-row deep groove ball bearing Bore diameter 120~180mm

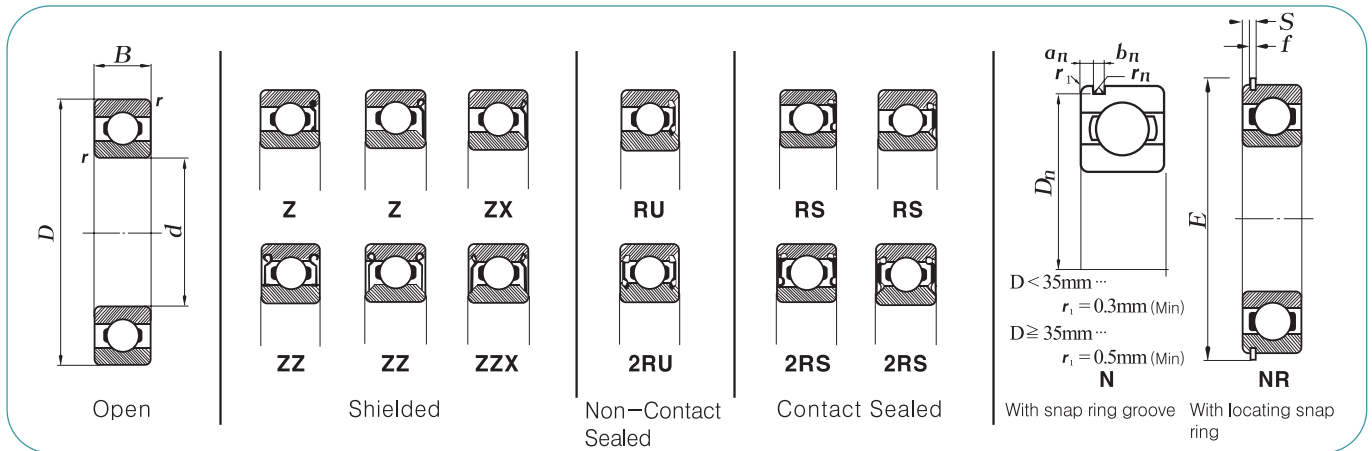

Boundary Dimensions ¹⁾				Bearing No.									Basic Load Ratings(kgf)		Limiting Speeds(rpm)		
d	D	B	r _s ¹⁾ Min	Open	Shielded		Non-Contact Sealed		Contact Sealed		snap ring groove	with snap ring	Dynamic C _e	Static C _o	Grease lub		Oil lub
					Z	ZZ	RU	2RU	RS	2RS					Open Z, ZZ, RU, 2RU	RS, 2RS	Open Z
120	215	40	2.1	6224	...ZX	...ZZX	...RU	...2RU	...RS	...2RS	-	-	15 800	13 400	2 900	1 700	3 400
120	260	55	3	6324	-	-	-	-	-	-	-	-	21 100	18 800	2 500	-	3 000
130	165	18	1.1	6826	-	-	-	-	-	-	-	-	3 760	4 200	3 600	-	4 300
130	180	24	1.5	6926	-	-	-	-	-	-	-	-	7 090	7 130	3 400	-	4 100
130	200	22	1.1	16026	-	-	-	-	-	-	-	-	7 270	7 630	3 000	-	3 600
130	200	33	2	6026	...ZX	...ZZX	...RU	...2RU	...RS	...2RS	...N	...NR	10 800	10 300	3 200	1 900	3 800
130	230	40	3	6226	...ZX	...ZZX	...RU	...2RU	...RS	...2RS	-	-	17 000	14 900	2 700	1 600	3 200
130	280	58	4	6326	-	-	-	-	-	-	-	-	23 400	21 800	2 300	-	2 700
140	175	18	1.1	6828	-	-	-	-	-	-	-	-	3 900	4 530	3 400	-	4 000
140	190	24	1.5	6928	-	-	-	-	-	-	-	-	7 270	7 630	3 200	-	3 800
140	210	22	1.1	16028	-	-	-	-	-	-	-	-	6 710	7 250	2 900	-	3 400
140	210	33	2	6028	...ZX	...ZZX	...RU	...2RU	...RS	...2RS	-	-	11 200	11 100	3 000	1 800	3 600
140	250	42	3	6228	...ZX	...ZZX	...RU	...2RU	...RS	...2RS	-	-	17 000	15 300	2 400	1 500	2 900
140	300	62	4	6328	-	-	-	-	-	-	-	-	25 800	25 100	2 100	-	2 500
150	190	20	1.1	6830	-	-	-	-	-	-	-	-	4 870	5 600	3 100	-	3 700
150	210	28	2	6930	-	-	-	-	-	-	-	-	9 520	9 620	2 900	-	3 400
150	225	24	1.1	16030	-	-	-	-	-	-	-	-	9 300	10 100	2 700	-	3 100
150	225	35	2.1	6030	...ZX	...ZZX	...RU	...2RU	...RS	...2RS	-	-	12 800	12 900	2 800	1 700	3 300
150	270	45	3	6230	-	-	-	-	-	-	-	-	18 000	17 100	2 200	-	2 700
150	320	65	4	6330	-	-	-	-	-	-	-	-	28 000	29 000	1 900	-	2 300
160	200	20	1.1	6832	-	-	-	-	-	-	-	-	4 930	5 800	2 900	-	3 400
160	220	28	2	6932	-	-	-	-	-	-	-	-	9 800	10 300	2 700	-	3 200
160	240	25	1.5	16032	-	-	-	-	-	-	-	-	10 100	11 000	2 600	-	3 100
160	240	38	2.1	6032	...ZX	...ZZX	...RU	...2RU	...RS	...2RS	-	-	13 900	13 800	2 600	1 500	3 000
160	290	48	3	6232	-	-	-	-	-	-	-	-	18 900	19 000	2 100	-	2 500
160	340	68	4	6332	-	-	-	-	-	-	-	-	28 300	29 200	1 800	-	2 200
170	215	22	1.1	6834	-	-	-	-	-	-	-	-	6 100	7 190	2 700	-	3 200
170	230	28	2	6934	-	-	-	-	-	-	-	-	10 100	11 000	2 600	-	3 100
170	260	28	1.5	16034	-	-	-	-	-	-	-	-	11 600	12 900	2 300	-	1 700
170	260	42	2.1	6034	-	-	-	-	-	-	-	-	16 400	16 400	2 400	-	2 800
170	310	52	4	6234	-	-	-	-	-	-	-	-	21 700	22 800	1 900	-	2 300
170	360	72	4	6334	-	-	-	-	-	-	-	-	33 300	36 200	1 700	-	2 000
180	225	22	1.1	6836	-	-	-	-	-	-	-	-	6 180	7 450	2 600	-	3 000
180	250	33	2	6936	-	-	-	-	-	-	-	-	12 500	13 100	2 400	-	2 800
180	280	31	2	16036	-	-	-	-	-	-	-	-	13 800	15 100	2 100	-	2 500

Remarks 1) Minimally required measurement of Chamfer.

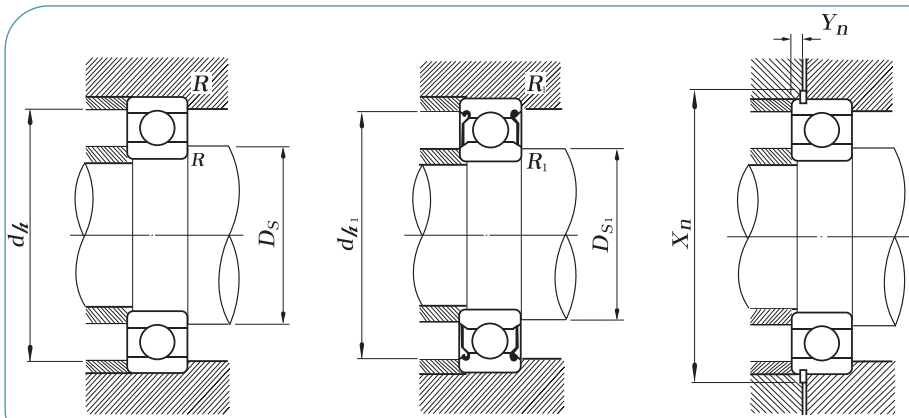

Dynamic equivalent radial load
 $P = XFr + YFa$

$\frac{Fa}{Co}$	e	$\frac{Fa}{Fr} \leq e$		$\frac{Fa}{Fr} > e$	
		X	Y	X	Y
0.014	0.19	1	0	0.56	2.30
0.028	0.22				1.99
0.056	0.26				1.71
0.084	0.28				1.55
0.11	0.30				1.45
0.17	0.34				1.31
0.28	0.38				1.15
0.42	0.42				1.04
0.56	0.44				1.00

Static equivalent radial load

$$P_0 = 0.6Fr + 0.5Fa$$

If $P_0 < Fr$, $P_0 = Fr$

Snap ring and groove dimension(mm)									Ref. Mounting dimension(mm)						Ref. weight (kg)	Bearing No.	
Dn	an	bn	rn	S	E	f	Xn	Yn	Open			Shielded · Sealed					
									Ds	dh	R	Ds1	dh1	R1			
Max	Max	±0.15	Max	Max	Max	±0.5	Ref.	Max	Max	Max	Min	Max	Max	Max			
-	-	-	-	-	-	-	-	-	132	203	2	132	143	203	2	5.15	6224
-	-	-	-	-	-	-	-	-	134	246	2.5	-	-	-	-	12.5	6324
-	-	-	-	-	-	-	-	-	137	158	1	-	-	-	-	0.939	6826
-	-	-	-	-	-	-	-	-	138.5	171.5	1.5	-	-	-	-	1.86	6926
-	-	-	-	-	-	-	-	-	137	193	1	-	-	-	-	2.69	16026
193.65	5.69	3.65	0.6	8.79	212.9	3.05	215	8.44	140	190	2	140	145	190	2	3.16	6026
-	-	-	-	-	-	-	-	-	144	216	2.5	144	153	216	2.5	5.82	6226
-	-	-	-	-	-	-	-	-	148	262	3	-	-	-	-	15.1	6326
-	-	-	-	-	-	-	-	-	147	168	1	-	-	-	-	1.00	6828
-	-	-	-	-	-	-	-	-	148.5	181.5	1.5	-	-	-	-	1.98	6928
-	-	-	-	-	-	-	-	-	147	203	1	-	-	-	-	2.86	16028
-	-	-	-	-	-	-	-	-	150	200	2	150	155	200	2	3.55	6028
-	-	-	-	-	-	-	-	-	154	236	2.5	154	168	236	2.5	7.45	6228
-	-	-	-	-	-	-	-	-	158	282	3	-	-	-	-	19.4	6328
-	-	-	-	-	-	-	-	-	157	183	1	-	-	-	-	1.40	6830
-	-	-	-	-	-	-	-	-	160	200	2	-	-	-	-	3.05	6930
-	-	-	-	-	-	-	-	-	157	218	1	-	-	-	-	3.58	16030
-	-	-	-	-	-	-	-	-	162	213	2	162	167	213	2	4.22	6030
-	-	-	-	-	-	-	-	-	164	256	2.5	-	-	-	-	9.41	6230
-	-	-	-	-	-	-	-	-	168	302	3	-	-	-	-	26.2	6330
-	-	-	-	-	-	-	-	-	167	193	1	-	-	-	-	1.45	6832
-	-	-	-	-	-	-	-	-	170	210	2	-	-	-	-	3.20	6932
-	-	-	-	-	-	-	-	-	168.5	231.5	1.5	-	-	-	-	4.25	16032
-	-	-	-	-	-	-	-	-	172	228	2	172	177	228	2	5.22	6032
-	-	-	-	-	-	-	-	-	174	276	2.5	-	-	-	-	14.3	6232
-	-	-	-	-	-	-	-	-	178	322	3	-	-	-	-	29.0	6332
-	-	-	-	-	-	-	-	-	177	208	1	-	-	-	-	1.90	6834
-	-	-	-	-	-	-	-	-	180	220	2	-	-	-	-	3.35	6934
-	-	-	-	-	-	-	-	-	178.5	251.5	1.5	-	-	-	-	5.75	16034
-	-	-	-	-	-	-	-	-	182	248	2	-	-	-	-	6.80	6034
-	-	-	-	-	-	-	-	-	188	292	3	-	-	-	-	17.5	6234
-	-	-	-	-	-	-	-	-	188	342	3	-	-	-	-	38.6	6334
-	-	-	-	-	-	-	-	-	187	218	1	-	-	-	-	2.00	6836
-	-	-	-	-	-	-	-	-	190	240	2	-	-	-	-	4.90	6936
-	-	-	-	-	-	-	-	-	190	270	2	-	-	-	-	7.55	16036

Single-row deep groove ball bearing Bore diameter 180~300mm

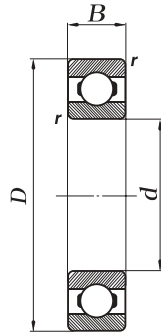

Boundary Dimensions(mm)				Bearing No.								Basic Load Ratings(kgf)		Limiting Speeds(rpm)			
d	D	B	r ¹⁾ Min	Open	Shielded		Non-Contact Sealed		Contact Sealed		snap ring groove	with snap ring	Dynamic C _e	Static C ₀	Grease lub		Oil lub
					Z	ZZ	RU	2RU	RS	2RS					Open Z,ZZ RU,2RU	RS, 2RS	Open Z
180	280	46	2.1	6036	-	-	-	-	-	-	-	-	18 500	19 800	2 200	-	2 600
180	320	52	4	6236	-	-	-	-	-	-	-	-	23 200	24 600	1 800	-	2 200
180	380	75	4	6336	-	-	-	-	-	-	-	-	36 100	41 500	1 600	-	1 900
190	240	24	1.5	6838	-	-	-	-	-	-	-	-	7 460	8 900	2 400	-	2 800
190	260	33	2	6938	-	-	-	-	-	-	-	-	12 900	14 100	2 300	-	2 700
190	290	31	2	16038	-	-	-	-	-	-	-	-	14 200	16 100	2 000	-	2 400
190	290	46	2.1	6038	-	-	-	-	-	-	-	-	19 200	20 500	2 100	-	2 500
190	340	55	4	6238	-	-	-	-	-	-	-	-	26 000	28 700	1 700	-	2 000
190	400	78	5	6338	-	-	-	-	-	-	-	-	36 200	42 300	1 500	-	1 800
200	250	24	1.5	6840	-	-	-	-	-	-	-	-	7 960	9 540	2 300	-	2 700
200	280	38	2.1	6940	-	-	-	-	-	-	-	-	15 900	17 100	2 100	-	2 500
200	310	34	2	16040	-	-	-	-	-	-	-	-	16 400	18 300	1 900	-	2 300
200	310	51	2.1	6040	-	-	-	-	-	-	-	-	22 200	24 800	1 900	-	2 300
200	360	58	4	6240	-	-	-	-	-	-	-	-	27 400	31 700	1 600	-	1 900
200	420	80	5	6340	-	-	-	-	-	-	-	-	41 900	51 600	1 300	-	1 600
220	270	24	1.5	6844	-	-	-	-	-	-	-	-	8 230	10 300	2 000	-	2 400
220	300	38	2.1	6944	-	-	-	-	-	-	-	-	16 400	18 400	1 900	-	2 200
220	340	37	2.1	16044	-	-	-	-	-	-	-	-	18 300	22 100	1 700	-	2 000
220	340	56	3	6044	-	-	-	-	-	-	-	-	24 000	27 600	1 700	-	2 000
220	400	65	4	6244	-	-	-	-	-	-	-	-	31 700	38 300	1 400	-	1 700
240	300	28	2	6848	-	-	-	-	-	-	-	-	11 000	13 700	1 800	-	2 100
240	320	38	2.1	6948	-	-	-	-	-	-	-	-	16 700	19 600	1 700	-	2 000
240	360	37	2.1	16048	-	-	-	-	-	-	-	-	18 800	23 300	1 600	-	1 800
240	360	56	3	6048	-	-	-	-	-	-	-	-	24 900	30 200	1 600	-	1 900
240	440	72	4	6248	-	-	-	-	-	-	-	-	34 600	43 900	1 200	-	1 500
260	320	28	2	6852	-	-	-	-	-	-	-	-	11 500	14 800	1 700	-	2 000
260	360	46	2.1	6952	-	-	-	-	-	-	-	-	21 700	26 900	1 500	-	1 800
260	400	44	3	16052	-	-	-	-	-	-	-	-	24 000	31 600	1 400	-	1 600
260	400	65	4	6052	-	-	-	-	-	-	-	-	29 700	38 400	1 400	-	1 700
280	350	33	2	6856	-	-	-	-	-	-	-	-	14 600	18 700	1 500	-	1 800
280	380	46	2.1	6956	-	-	-	-	-	-	-	-	22 300	28 800	1 400	-	1 700
280	420	44	3	16056	-	-	-	-	-	-	-	-	24 700	33 700	1 300	-	1 500
280	420	65	4	6056	-	-	-	-	-	-	-	-	30 800	41 600	1 300	-	1 500
300	380	38	2.1	6860	-	-	-	-	-	-	-	-	18 300	23 500	1 400	-	1 600
300	420	56	3	6960	-	-	-	-	-	-	-	-	28 200	38 500	1 300	-	1 500

Remarks Minimally required measurement of Chamfer.

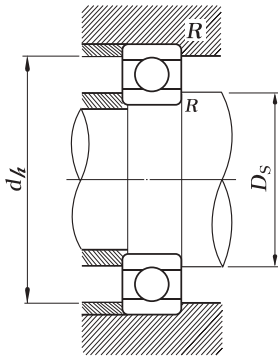

Dynamic equivalent radial load
 $P = XFr + YFa$

$\frac{Fa}{Co}$	e	$\frac{Fa}{Fr} \leq e$		$\frac{Fa}{Fr} > e$	
		X	Y	X	Y
0.014	0.19				2.30
0.028	0.22				1.99
0.056	0.26				1.71
0.084	0.28	1	0	0.56	1.55
0.11	0.30				1.45
0.17	0.34				1.31
0.28	0.38				1.15
0.42	0.42				1.04
0.56	0.44				1.00

Static equivalent radial load

$$P_0 = 0.6Fr + 0.5Fa$$

If $P_0 < Fr$, $P_0 = Fr$

Snap ring and groove dimension(mm)									Ref. Mounting dimension(mm)						Ref. weight (kg)	Bearing No.	
Dn	an	bn	rn	S	E	f	Xn	Yn	Open			Shielded · Sealed					
									Ds	dh	R	Ds_1	dh_1	R_1			
Max	Max	± 0.15	Max	Max	Max	± 0.5	Ref.	Max	Max	Max	Min	Max	Max	Max			
-	-	-	-	-	-	-	-	-	192	268	2	-	-	-	-	10.3	6036
-	-	-	-	-	-	-	-	-	198	302	3	-	-	-	-	18.3	6236
-	-	-	-	-	-	-	-	-	198	362	3	-	-	-	-	44.7	6336
-	-	-	-	-	-	-	-	-	198.5	231.5	1.5	-	-	-	-	2.60	6838
-	-	-	-	-	-	-	-	-	200	250	2	-	-	-	-	5.20	6938
-	-	-	-	-	-	-	-	-	200	280	2	-	-	-	-	7.85	16038
-	-	-	-	-	-	-	-	-	202	278	2	-	-	-	-	10.8	6038
-	-	-	-	-	-	-	-	-	208	322	3	-	-	-	-	23.0	6238
-	-	-	-	-	-	-	-	-	212	378	4	-	-	-	-	51.5	6338
-	-	-	-	-	-	-	-	-	208.5	241.5	1.5	-	-	-	-	2.700	6840
-	-	-	-	-	-	-	-	-	212	268	2	-	-	-	-	7.30	6940
-	-	-	-	-	-	-	-	-	210	300	2	-	-	-	-	10.1	16040
-	-	-	-	-	-	-	-	-	212	298	2	-	-	-	-	14.0	6040
-	-	-	-	-	-	-	-	-	218	342	3	-	-	-	-	28.2	6240
-	-	-	-	-	-	-	-	-	222	398	4	-	-	-	-	28.0	6340
-	-	-	-	-	-	-	-	-	228.5	261.5	1.5	-	-	-	-	3.00	6844
-	-	-	-	-	-	-	-	-	232	288	2	-	-	-	-	7.90	6944
-	-	-	-	-	-	-	-	-	232	328	2	-	-	-	-	13.2	16044
-	-	-	-	-	-	-	-	-	234	326	2.5	-	-	-	-	18.3	6044
-	-	-	-	-	-	-	-	-	238	382	3	-	-	-	-	37.0	6244
-	-	-	-	-	-	-	-	-	250	290	2	-	-	-	-	4.50	6848
-	-	-	-	-	-	-	-	-	252	308	2	-	-	-	-	8.50	6948
-	-	-	-	-	-	-	-	-	252	348	2	-	-	-	-	14.1	16048
-	-	-	-	-	-	-	-	-	254	346	2.5	-	-	-	-	19.7	6048
-	-	-	-	-	-	-	-	-	258	422	3	-	-	-	-	51.0	6248
-	-	-	-	-	-	-	-	-	270	310	2	-	-	-	-	4.80	6852
-	-	-	-	-	-	-	-	-	272	348	2	-	-	-	-	14.4	6952
-	-	-	-	-	-	-	-	-	274	386	2.5	-	-	-	-	21.6	16052
-	-	-	-	-	-	-	-	-	278	382	3	-	-	-	-	29.3	6052
-	-	-	-	-	-	-	-	-	290	340	2	-	-	-	-	7.40	6856
-	-	-	-	-	-	-	-	-	292	368	2	-	-	-	-	15.1	6956
-	-	-	-	-	-	-	-	-	294	406	2.5	-	-	-	-	22.9	16056
-	-	-	-	-	-	-	-	-	298	402	3	-	-	-	-	31.0	6056
-	-	-	-	-	-	-	-	-	312	368	2	-	-	-	-	10.5	6860
-	-	-	-	-	-	-	-	-	314	406	2.5	-	-	-	-	24.1	6960

Single-row deep groove ball bearing Bore diameter 300~600mm

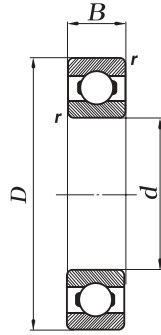

Boundary Dimensions ⁽¹⁾				Bearing No.								Basic Load Ratings(kgf)		Limiting Speeds(rpm)			
d	D	B	r ^s Min	Open	Shielded		Non-Contact Sealed		Contact Sealed		with snap ring groove	with locating snap ring	Dynamic C _e	Static C ₀	Grease lub		Oil lub
					Z	ZZ	RU	2RU	RS	2RS					Open Z,ZZ RU,2RU	RS, 2RS	Open Z
300	460	50	4	16060	-	-	-	-	-	-	-	-	28 900	41 300	1 100	-	1 400
300	460	74	4	6060	-	-	-	-	-	-	-	-	36 200	49 100	1 200	-	1 400
320	400	38	2.1	6864	-	-	-	-	-	-	-	-	18 500	24 400	1 300	-	1 500
320	440	56	3	6964	-	-	-	-	-	-	-	-	29 000	41 200	1 200	-	1 400
320	480	50	4	16064	-	-	-	-	-	-	-	-	29 700	44 100	1 100	-	1 300
320	480	74	4	6064	-	-	-	-	-	-	-	-	35 900	49 700	1 100	-	1 300
340	420	38	2.1	6868	-	-	-	-	-	-	-	-	18 800	25 400	1 200	-	1 400
340	460	56	3	6968	-	-	-	-	-	-	-	-	28 700	41 500	1 100	-	1 300
340	520	57	4	16068	-	-	-	-	-	-	-	-	34 200	52 200	980	-	1 200
340	520	82	5	6068	-	-	-	-	-	-	-	-	45 000	67 400	980	-	1 200
360	440	38	2.1	6872	-	-	-	-	-	-	-	-	19 600	27 400	1 100	-	1 300
360	480	56	3	6972	-	-	-	-	-	-	-	-	29 500	44 100	1 000	-	1 200
360	540	57	4	16072	-	-	-	-	-	-	-	-	35 200	55 700	900	-	1 100
360	540	82	5	6072	-	-	-	-	-	-	-	-	44 700	68 100	920	-	1 100
380	480	46	2.1	6876	-	-	-	-	-	-	-	-	24 900	36 600	980	-	1 200
380	520	65	4	6976	-	-	-	-	-	-	-	-	35 900	56 200	920	-	1 100
380	560	82	5	6076	-	-	-	-	-	-	-	-	46 600	73 900	860	-	1 000
400	500	46	2.1	6880	-	-	-	-	-	-	-	-	25 300	38 200	920	-	1 100
400	540	65	4	6980	-	-	-	-	-	-	-	-	37 000	59 900	860	-	1 000
400	600	90	5	6080	-	-	-	-	-	-	-	-	51 800	84 000	780	-	920
420	520	46	2.1	6884	-	-	-	-	-	-	-	-	25 800	39 700	860	-	1 000
420	620	90	5	6084	-	-	-	-	-	-	-	-	54 100	91 200	740	-	870
440	540	46	2.1	6888	-	-	-	-	-	-	-	-	26 200	41 200	810	-	950
460	580	56	3	6892	-	-	-	-	-	-	-	-	32 100	52 700	740	-	870
480	600	56	3	6896	-	-	-	-	-	-	-	-	32 700	54 900	690	-	820
500	620	56	3	68/500	-	-	-	-	-	-	-	-	33 300	57 200	650	-	770
530	650	56	3	68/530	-	-	-	-	-	-	-	-	33 800	59 300	600	-	710
560	680	56	3	68/560	-	-	-	-	-	-	-	-	34 200	61 400	550	-	650
600	730	60	3	68/600	-	-	-	-	-	-	-	-	38 400	72 100	490	-	580

Remarks Minimally required measurement of Chamfer.

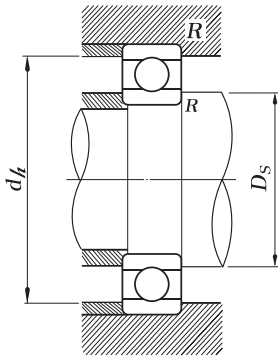

Dynamic equivalent radial load
 $P = XFr + YFa$

$\frac{Fa}{Co}$	e	$\frac{Fa}{Fr} \leq e$		$\frac{Fa}{Fr} > e$	
		X	Y	X	Y
0.014	0.19				2.30
0.028	0.22				1.99
0.056	0.26				1.71
0.084	0.28	1	0	0.56	1.55
0.11	0.30				1.45
0.17	0.34				1.31
0.28	0.38				1.15
0.42	0.42				1.04
0.56	0.44				1.00

Static equivalent radial load

$$P_0 = 0.6Fr + 0.5Fa$$

If $P_0 < Fr$, $P_0 = Fr$

Snap ring and groove dimension(mm)									Ref. Mounting dimension(mm)						Ref. weight (kg)	Bearing No.	
Dn	an	bn	rn	S	E	f	Xn	Yn	Open			Shielded · Sealed					
									Ds	dh	R	Ds_1	dh_1	R_1			
Max	Max	± 0.15	Max	Max	Max	± 0.5	Ref.	Max	Max	Max	Min	Max	Max	Max			
-	-	-	-	-	-	-	-	-	318	442	3	-	-	-	-	32.2	16060
-	-	-	-	-	-	-	-	-	318	442	3	-	-	-	-	44.0	6060
-	-	-	-	-	-	-	-	-	332	388	2	-	-	-	-	11.0	6864
-	-	-	-	-	-	-	-	-	334	426	2.5	-	-	-	-	25.5	6964
-	-	-	-	-	-	-	-	-	338	462	3	-	-	-	-	33.9	16064
-	-	-	-	-	-	-	-	-	338	462	3	-	-	-	-	46.0	6064
-	-	-	-	-	-	-	-	-	352	408	2	-	-	-	-	11.5	6868
-	-	-	-	-	-	-	-	-	354	446	2.5	-	-	-	-	26.8	6968
-	-	-	-	-	-	-	-	-	358	502	3	-	-	-	-	46.8	16068
-	-	-	-	-	-	-	-	-	362	498	4	-	-	-	-	61.8	6068
-	-	-	-	-	-	-	-	-	372	428	2	-	-	-	-	12.0	6872
-	-	-	-	-	-	-	-	-	374	466	2.5	-	-	-	-	28.2	6972
-	-	-	-	-	-	-	-	-	378	522	3	-	-	-	-	49.0	16072
-	-	-	-	-	-	-	-	-	382	518	4	-	-	-	-	64.7	6072
-	-	-	-	-	-	-	-	-	392	468	2	-	-	-	-	20.0	6876
-	-	-	-	-	-	-	-	-	398	502	3	-	-	-	-	40.8	6976
-	-	-	-	-	-	-	-	-	402	538	4	-	-	-	-	67.6	6076
-	-	-	-	-	-	-	-	-	412	488	2	-	-	-	-	20.5	6880
-	-	-	-	-	-	-	-	-	418	522	3	-	-	-	-	42.7	6980
-	-	-	-	-	-	-	-	-	422	578	4	-	-	-	-	87.7	6080
-	-	-	-	-	-	-	-	-	432	508	2	-	-	-	-	21.5	6884
-	-	-	-	-	-	-	-	-	442	598	4	-	-	-	-	91.2	6084
-	-	-	-	-	-	-	-	-	452	528	2	-	-	-	-	22.5	6888
-	-	-	-	-	-	-	-	-	474	566	2.5	-	-	-	-	35.0	6892
-	-	-	-	-	-	-	-	-	494	586	2.5	-	-	-	-	36.5	6896
-	-	-	-	-	-	-	-	-	514	606	2.5	-	-	-	-	37.5	68/500
-	-	-	-	-	-	-	-	-	544	636	2.5	-	-	-	-	39.5	68/530
-	-	-	-	-	-	-	-	-	574	666	2.5	-	-	-	-	42.0	68/560
-	-	-	-	-	-	-	-	-	614	716	2.5	-	-	-	-	52.0	68/600

GMB

TAPERED ROLLER BEARING

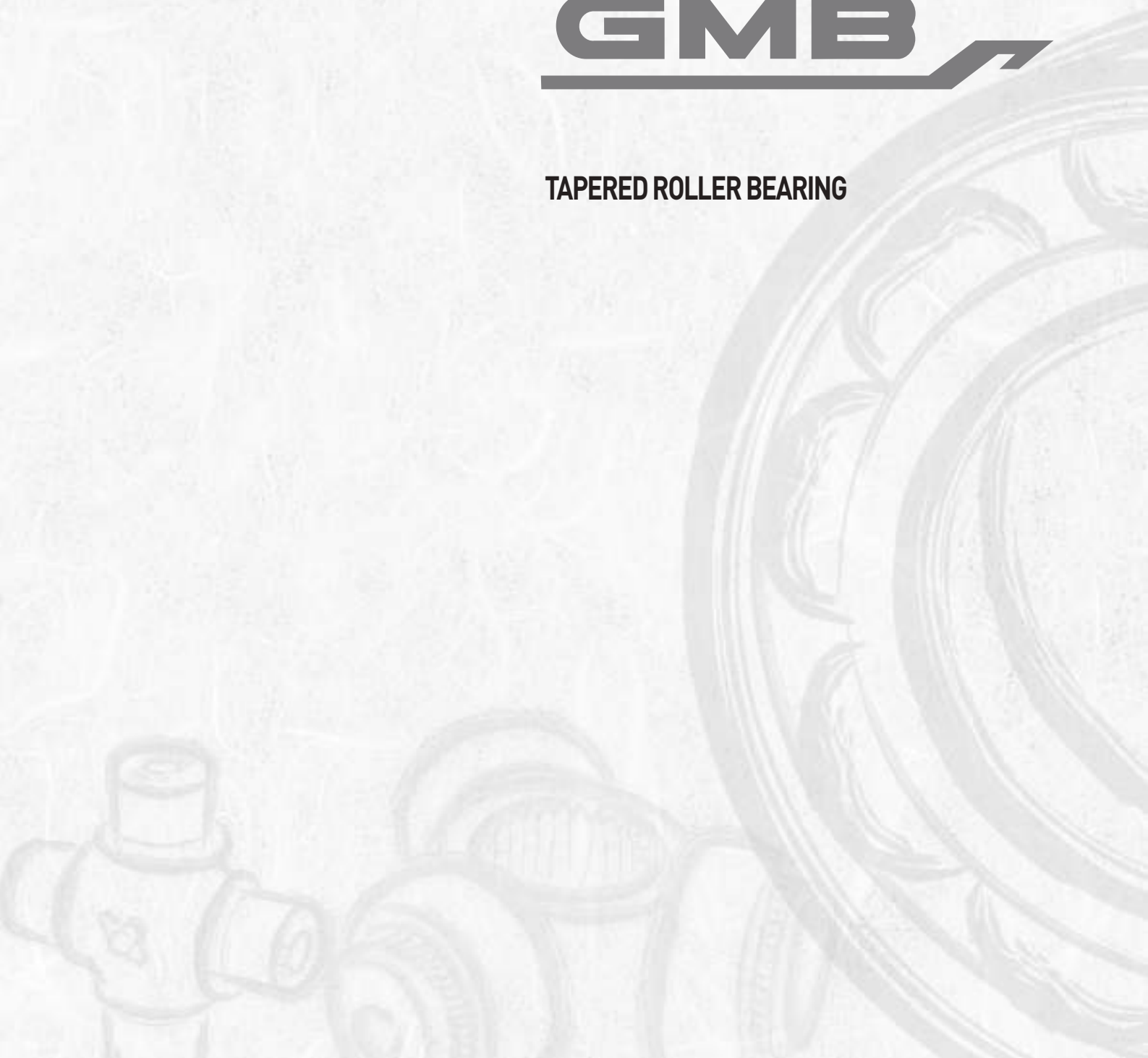

Metric series

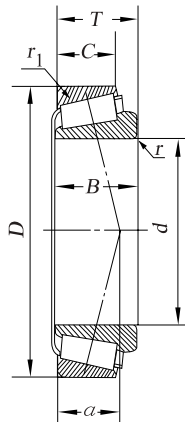

30000 Model

d 15 ~ 30mm

d	Boundary dimensions mm				Basic load ratings /kN		Limiting speeds /(r/min)		Mass /Kg		e	Y	Y_0	30000 Model	ISO355
	D	T	B	C	C_r	C_{or}	grease	oil	W ≈						
5	42	14.25	13	11	32.8	21.5	9000	12000	0.094	0.29	2.1	1.2	30302	2BF	
17	40	13.25	12	11	20.8	21.8	9000	12000	0.079	0.35	1.7	1	30203	2DB	
	47	15.25	14	12	28.2	27.2	8500	11000	0.129	0.29	2.1	1.2	30303	2FB	
20	47	20.25	19	16	35.2	36.2	8500	11000	0.173	0.29	2.1	1.2	32303	2FD	
	37	12	12	9	13.2	17.5	9500	13000	0.056	0.32	1.9	1	32904	2BD	
	42	15	15	12	25.0	28.2	8500	11000	0.095	0.37	1.6	0.9	32004	3CC	
	47	15.25	14	12	28.2	30.5	8000	10000	0.126	0.35	1.7	1	30204	2DB	
	52	16.25	15	13	33.0	33.2	7500	9500	0.165	0.3	2	1.1	30304	2BF	
22	52	22.25	21	18	42.8	46.2	7500	9500	0.230	0.3	2	1.1	32304	2FD	
	40	12	12	9	15.0	20.2	8500	11000	0.065	0.32	1.9	1	329/22	2BC	
	44	15	15	11.5	26.0	30.2	8000	10000	0.100	0.40	1.5	0.8	320/22	3CC	
	42	12	12	9	16.0	21.0	6300	10000	0.064	0.32	1.9	1	32905	2BD	
25	47	15	15	11.5	28.0	34.0	7500	9500	0.11	0.43	1.4	0.8	32005	4CC	
	47	17	17	14	32.5	42.5	7500	9500	0.129	0.29	2.1	1.1	33005	2CE	
	52	16.25	15	13	32.2	37.0	7000	9000	0.154	0.37	1.6	0.9	30205	3CC	
	52	22	22	18	47.0	55.8	7000	9000	0.216	0.35	1.7	0.9	33205	2DE	
	62	18.25	17	15	46.8	48.0	6300	8000	0.263	0.3	2	1.1	30305	2FB	
28	62	18.25	17	13	40.5	46.0	6300	8000	0.262	0.83	0.7	0.4	31305	7FB	
	62	25.25	24	20	61.5	68.8	6300	8000	0.368	0.3	2	1.1	32305	2FD	
	45	12	12	9	16.8	22.8	7500	9500	0.069	0.32	1.9	1	329/28	2BD	
30	52	16	16	12	31.5	40.5	6700	8500	0.142	0.43	1.4	0.8	320/28	4CC	
	58	24	24	19	58.0	68.2	6300	8000	0.286	0.34	1.8	1.0	332/28	2DE	
	47	12	12	9	17.0	23.2	7000	9000	0.072	0.32	1.9	1	32906	2BD	
	55	47	16	14	27.8	35.5	6300	8000	0.16	0.26	2.3	1.3	32006X2	-	
	55	17	17	13	35.8	46.8	6300	8000	0.170	0.43	1.4	0.8	32006	4CC	
	55	20	20	16	43.8	58.8	6300	8000	0.201	0.29	2.1	1.1	33006	2CE	
	62	17.25	16	14	43.2	50.5	6000	7500	0.231	0.37	1.6	0.9	30206	3DB	
	62	21.25	20	17	51.8	63.8	6000	7500	0.287	0.37	1.6	0.9	32206	3DC	
30	62	25	25	19	63.8	75.5	6000	7500	0.342	0.34	1.8	1	33206	2DE	
	72	20.75	19	16	59.0	63.0	5600	7000	0.387	0.31	1.9	1.1	30306	2FB	
	72	20.75	19	14	52.5	60.5	5600	7000	0.392	0.83	0.7	0.4	31306	7FB	
	72	28.75	27	23	81.5	96.5	5600	7000	0.562	0.31	1.9	1.1	32306	2FD	

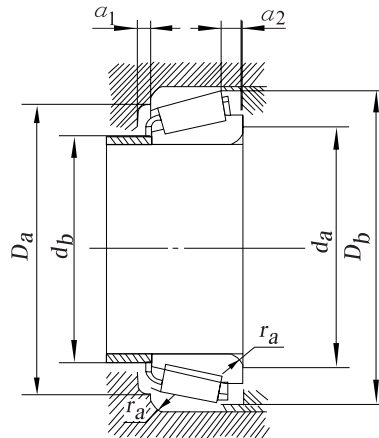

<i>d</i>	<i>a</i> ≈	<i>r_s</i> min	<i>r_{1s}</i> min	<i>d_a</i> min	<i>d_b</i> max	<i>D_a</i> min	<i>D_a</i> max	<i>D_b</i> min	<i>a₁</i> min	<i>a₂</i> min	<i>r_{as}</i> max	<i>r_{bs}</i> max	
15	9.6	1	1	21	22	36	36	38	2	3.5	1	1	7302 E
17	9.9	1	1	23	23	34	34	37	2	2.5	1	1	7203 E
	10.4	1	1	23	25	40	41	43	3	3.5	1	1	7303 E
	12.3	1	1	23	24	39	41	43	3	4.5	1	1	7603 E
20	8.2	0.3	0.3	–	–	–	–	–	–	–	0.3	0.3	2007904 E
	10.3	0.6	0.6	25	25	36	37	39	3	3	0.6	0.6	2007104 E
	11.2	1	1	26	27	40	41	43	2	3.5	1	1	7204 E
	11.1	1.5	1.5	27	28	44	45	48	3	3.5	1.5	1.5	7304 E
	13.6	1.5	1.5	27	26	43	45	48	3	4.5	1.5	1.5	7604 E
22	8.5	0.3	0.3	–	–	–	–	–	–	–	0.3	0.3	20079/22 F
	10.8	0.6	0.6	27	27	38	39	41	3	3.5	0.6	0.6	20071/22 E
25	8.7	0.3	0.3	–	–	–	–	–	–	–	0.3	0.3	2007905 E
	11.6	0.6	0.6	30	30	40	42	44	3	3.5	0.6	0.6	2007105 E
	11.1	0.6	0.6	30	30	40	42	45	3	3	0.6	0.6	3007105 E
	12.5	1	1	31	31	44	46	48	2	3.5	1	1	7205 E
	14.0	1	1	31	30	43	46	49	4	4	1	1	3007205 E
	13.0	1.5	1.5	32	34	54	55	58	3	3.5	1.5	1.5	7305 E
	20.1	1.5	1.5	32	31	47	55	59	3	5.5	1.5	1.5	27305 E
28	15.9	1.5	1.5	32	32	52	55	58	3	5.5	1.5	1.5	7605 E
	9.0	0.3	0.3	–	–	–	–	–	–	–	0.3	0.3	20079/28 E
	12.6	1	1	34	33	45	46	49	3	4	1	1	20071/28 E
30	15.0	1	1	34	33	49	52	55	4	5	1	1	30072/28 E
	9.2	0.3	0.3	–	–	–	–	–	–	–	0.3	0.3	2007906 E
	12.0	1	1	–	–	–	–	–	3	5	–	–	2007106
	13.3	1	1	36	35	48	49	52	3	4	1	1	2007106 E
	12.8	1	1	36	35	48	49	52	3	4	1	1	3007106 E
	13.8	1	1	36	37	53	56	58	2	3.5	1	1	7206 E
	15.6	1	1	36	36	52	56	58	3	4.5	1	1	7506 E
	15.7	1	1	36	36	53	56	59	5	5.5	1	1	3007206 E
	15.3	1.5	1.5	37	40	62	65	66	3	5	1.5	1.5	7306 E
	23.1	1.5	1.5	37	37	55	65	68	3	7	1.5	1.5	27306 E
18.9	1.5	1.5	37	38	59	65	66	4	6	1.5	1.5	7606 E	

Metric series

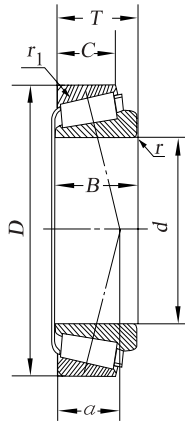

30000 Model

d 32 ~ 45mm

d	Boundary dimensions mm				Basic load ratings /kN		Limiting speeds /(r/min)		Mass /Kg	e	Y	Y_0	30000 Model	ISO355
	D	T	B	C	C_r	C_{or}	grease	oil	W ≈					
32	52	14	14	10	23.8	32.5	6300	8000	0.106	0.32	1.9	1	329/32	2BD
	58	17	17	13	36.5	49.2	6000	7500	0.187	0.45	1.3	0.7	320/32	4CC
	65	26	26	20.5	68.8	82.2	5600	7000	0.385	0.35	1.7	1	332/32	2DE
35	55	14	14	11.5	25.8	34.8	6000	7500	0.114	0.29	2.1	1.1	32907	2BD
	62	18	17	15	33.8	47.2	5600	7000	0.21	0.29	2.1	1.1	32007 X2	-
	62	18	18	14	43.2	59.2	5600	7000	0.224	0.44	1.4	0.8	32007	4CC
	62	21	21	17	46.8	63.2	5600	7000	0.254	0.31	2	1.1	33007	2CE
	72	18.25	17	15	54.2	63.5	5300	6700	0.331	0.37	1.6	0.9	30207	3DB
	72	24.25	23	19	70.5	89.5	5300	6700	0.445	0.37	1.6	0.9	32207	3DC
	72	28	28	22	82.5	102	5300	6700	0.515	0.35	1.7	0.9	33207	2DE
40	80	22.75	21	18	75.2	82.5	5000	6300	0.515	0.31	1.9	1.1	30307	2FB
	80	22.75	21	15	65.8	76.8	5000	6300	0.514	0.83	0.7	0.4	31307	7FB
	80	32.75	31	25	99.0	118	5000	6300	0.763	0.31	1.9	1.1	32307	2FE
	62	15	14	12	21.2	28.2	5600	7000	0.14	0.28	2.1	1.2	32908 X2	-
	62	15	15	12	31.5	46.0	5600	7000	0.155	0.29	2.1	1.1	32908	2BC
	68	19	18	16	39.8	55.2	5300	6700	0.27	0.3	2	1.1	32008 X2	-
	68	19	19	14.5	51.8	71.0	5300	6700	0.267	0.38	1.6	0.9	32008	3CD
	68	22	22	18	60.2	79.5	5300	6700	0.306	0.28	2.1	1.2	33008	2BE
	75	26	26	20.5	84.8	110	5000	6300	0.496	0.36	1.7	0.9	33108	2CE
	80	19.75	18	16	63.0	74.0	5000	6300	0.422	0.37	1.6	0.9	30208	3DB
45	80	24.75	23	19	77.8	97.2	5000	6300	0.532	0.37	1.6	0.9	32208	3DC
	80	32	32	25	105	135	5000	6300	0.715	0.36	1.7	0.9	33208	2DE
	90	25.25	23	20	90.8	108	4500	5600	0.747	0.35	1.7	1	30308	2FB
	90	25.25	23	17	81.5	96.5	4500	5600	0.727	0.83	0.7	0.4	31308	7FB
	90	35.25	33	27	115	148	4500	5600	1.04	0.35	1.7	1	32308	2FD
	68	15	14	12	22.2	32.8	5300	6700		0.31	1.9	1.1	32909 X2	-
	68	15	15	12	32.0	48.5	5300	6700	0.180	0.32	1.9	1	32909	2BC
	75	20	19	16	44.5	62.5	5000	6300	0.32	0.3	2	1.1	32009 X2	-
	75	20	20	15.5	58.5	81.5	5000	6300	0.337	0.39	1.5	0.8	32009	3CC
	75	24	24	19	72.5	100	5000	6300	0.398	0.32	1.9	1	33009	2CE
45	80	26	26	20.5	87.0	118	4500	5600	0.535	0.38	1.6	1	33109	3CE
	85	20.75	19	16	67.8	83.5	4500	5600	0.474	0.4	1.5	0.8	30209	3DB
	85	24.75	23	19	80.8	105	4500	5600	0.573	0.4	1.5	0.8	32209	3DC
	85	32	32	25	110	145	4500	5600	0.771	0.39	1.5	0.9	33209	3DE
	100	27.25	25	22	108	130	4000	5000	0.984	0.35	1.7	1	30309	2FB

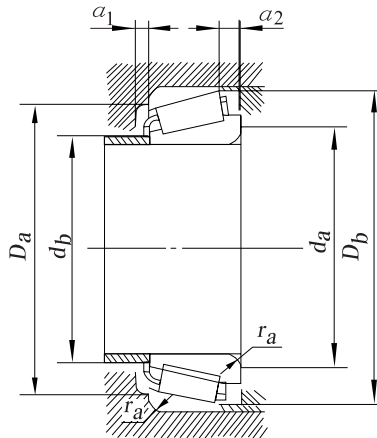

<i>d</i>	<i>a</i> ≈	<i>r_s</i> min	<i>r_{1s}</i> min	<i>d_a</i> min	<i>d_b</i> max	<i>D_a</i> min	<i>D_a</i> max	<i>D_b</i> min	<i>a₁</i> min	<i>a₂</i> min	<i>r_{as}</i> max	<i>r_{bs}</i> max	
32	10.2	0.6	0.6	37	37	46	47	49	3	4	0.6	0.6	20079/32 E
	14.0	1	1	38	38	50	52	55	3	4	1	1	20071/32 E
	16.6	1	1	38	38	55	59	62	5	5.5	1	1	30072/32 E
35	10.1	0.6	0.6	40	40	49	50	52	3	2.5	0.6	0.6	2007907 E
	14.0	1	1	—	—	—	—	—	3	5	1	1	2007107
	15.1	1	1	41	40	54	56	59	4	4	1	1	2007107 E
	13.5	1	1	41	41	54	56	59	3	4	1	1	3007107 E
	15.3	1.5	1.5	42	44	62	65	67	3	3.5	1.5	1.5	7207 E
	17.9	1.5	1.5	42	42	61	65	68	3	5.5	1.5	1.5	7507 E
	18.2	1.5	1.5	42	42	70	65	68	5	6	1.5	1.5	3007207 E
	16.8	2	1.5	44	45	62	71	74	3	5	2	1.5	7307 E
40	25.8	2	1.5	44	42	66	71	76	4	8	2	1.5	27307 E
	20.4	2	1.5	44	43	66	71	74	4	8.5	2	1.5	7607 E
	12.0	0.6	0.6	—	—	—	—	—	3	5	0.6	0.6	2007908
	11.1	0.6	0.6	45	45	55	57	59	3	3	0.6	0.6	2007908 E
	15.0	1	1	—	—	—	—	—	3	5	1	1	2007108
	14.9	1	1	46	46	60	62	65	4	4.5	1	1	2007108 E
	14.1	1	1	46	46	60	62	64	3	4	1	1	3007108 E
	18.0	1.5	1.5	47	47	65	68	71	4	5.5	1.5	1.5	3007708 E
	16.9	1.5	1.5	47	49	69	73	75	3	4	1.5	1.5	7208 E
	18.9	1.5	1.5	47	48	68	73	75	3	6	1.5	1.5	7508 E
45	20.8	1.5	1.5	47	47	67	73	76	5	7	1.5	1.5	3007208 E
	19.5	2	1.5	49	52	77	81	84	3	5.5	2	1.5	7308 E
	29.0	2	1.5	49	48	71	81	87	4	8.5	2	1.5	27308 E
	23.3	2	1.5	49	49	73	81	83	4	8.5	2	1.5	7608 E
	13.0	0.6	0.6	—	—	—	—	—	3	5	0.6	0.6	2007909
	12.2	0.6	0.6	50	50	61	63	65	3	3	0.6	0.6	2007909 E
	16.0	1	1	—	—	—	—	—	4	6	1	1	2007109
	16.5	1	1	51	51	67	69	72	4	4.5	1	1	2007109 E
	15.9	1	1	51	51	67	69	72	4	5	1	1	3007109 E
	19.1	1.5	1.5	52	52	69	73	77	4	5.5	1.5	1.5	3007709 E
	18.6	1.5	1.5	52	53	74	78	80	3	5	1.5	1.5	7209 E
	20.1	1.5	1.5	52	53	73	78	81	3	6	1.5	1.5	7509 E
	21.9	1.5	1.5	52	52	72	78	81	5	7	1.5	1.5	3007209 E
	21.3	2	1.5	54	59	86	91	94	3	5.5	2	1.5	7309 E

Metric series

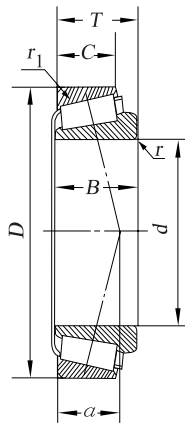

30000 Model

d 45 ~ 60mm

d	Boundary dimensions mm				Basic load ratings /kN		Limiting speeds /(r/min)		Mass /Kg	e	Y	Y_0	30000 Model	ISO355
	D	T	B	C	C_r	C_{or}	grease	oil	W ≈					
45	100	27.25	25	18	95.5	115	4000	5000	0.944	0.83	0.7	0.4	31309	7FB
	100	38.25	36	30	145	188	4000	5000	1.40	0.35	1.7	1	32309	2FD
50	72	15	14	12	22.2	32.8	5000	6300	0.7	0.35	1.7	0.9	32910 X2	-
	72	15	15	12	36.8	56.0	5000	6300	0.181	0.34	1.8	1	32910	2BC
	80	20	19	16	45.8	66.2	4500	5600	0.31	0.32	1.9	1	32010 X2	-
	80	20	20	15.5	61.0	89.0	4500	5600	0.366	0.42	1.4	0.8	32010	3CC
	80	24	24	19	76.8	110	4500	5600	0.433	0.32	1.9	1	33010	2CE
	85	26	26	20	89.2	125	4300	5300	0.572	0.41	1.5	0.8	33110	3CE
	90	21.75	20	17	73.2	92.0	4300	5300	0.529	0.42	1.4	0.8	30210	3DB
	90	24.75	23	19	82.8	108	4300	5300	0.626	0.42	1.4	0.8	32210	3DC
	90	32	32	24.5	112	155	4300	5300	0.825	0.41	1.5	0.8	33210	3DE
	110	29.25	27	23	130	158	3800	4800	1.28	0.35	1.7	1	30310	2FB
55	110	29.25	27	19	108	128	3800	4800	1.21	0.83	0.7	0.4	31310	7FB
	110	42.25	40	33	178	235	3800	4800	1.89	0.35	1.7	1	32310	2FD
	80	17	17	14	41.5	66.8	4800	6000	0.262	0.31	1.9	1.1	32911	2BC
	90	23	22	19	63.8	93.2	4000	5000	0.53	0.31	1.9	1.1	32011 X2	-
	90	23	23	17.5	80.2	118	4000	5000	0.551	0.41	1.5	0.8	32011	3CC
	90	27	27	21	94.8	145	4000	5000	0.651	0.31	1.9	1.1	33011	2CE
	95	30	30	23	115	165	3800	4800	0.843	0.37	1.6	0.9	33111	3CE
	100	22.75	21	18	90.8	115	3800	4800	0.713	0.4	1.5	0.8	30211	3DB
	100	26.75	25	21	108	142	3800	4800	0.853	0.4	1.5	0.8	32211	3DC
	100	35	35	27	142	198	3800	4800	1.15	0.4	1.5	0.8	33211	3DE
60	120	31.5	29	25	152	188	3400	4300	1.63	0.35	1.7	1	30311	2FB
	120	31.5	29	21	130	158	3400	4300	1.56	0.83	0.7	0.4	31311	7FB
	120	45.5	43	35	202	270	3400	4300	2.37	0.35	1.7	1	32311	2FD
	85	17	16	14	34.5	56.5	4000	5000	0.24	0.38	1.6	0.9	32912X2	-
	85	17	17	14	46.0	73.0	4000	5000	0.279	0.33	1.8	1	32912	2BC
	95	23	22	19	64.8	98.0	3800	4800	0.56	0.33	1.8	1	32012X2	-
	95	23	23	17.5	81.8	122	3800	4800	0.584	0.43	1.4	0.8	32012	4CC
	95	27	27	21	96.8	150	3800	4800	0.691	0.33	1.8	1	33012	2CE
	100	30	30	23	118	172	3600	4500	0.895	0.4	1.5	0.8	33112	3CE
	110	23.75	22	19	102	130	3600	4500	0.904	0.4	1.5	0.8	30212	3EB
60	110	29.75	28	24	132	180	3600	4500	1.17	0.4	1.5	0.8	32212	3EC
	110	38	38	29	165	230	3600	4500	1.51	0.4	1.5	0.8	33212	3EE
	130	33.5	31	26	170	210	3200	4000	1.99	0.35	1.7	1	30312	2FB

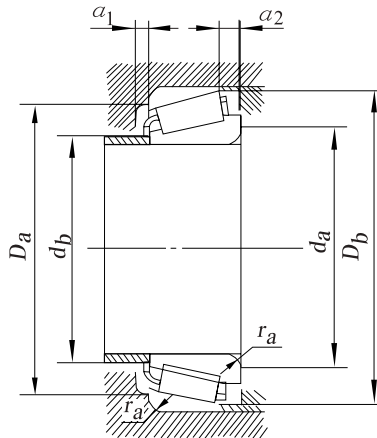

<i>d</i>	<i>a</i> ≈	<i>r_s</i> min	<i>r_{1s}</i> min	<i>d_a</i> min	<i>d_b</i> max	<i>D_a</i> min	<i>D_a</i> max	<i>D_b</i> min	<i>a₁</i> min	<i>a₂</i> min	<i>r_{as}</i> max	<i>r_{bs}</i> max	
45	31.7	2	1.5	54	54	79	91	96	4	9.5	2.0	1.5	27309 E
	25.6	2	1.5	54	56	82	91	93	4	8.5	2.0	1.5	7609 E
50	15.0	0.6	0.6	–	–	–	–	–	3	5	0.6	0.6	2007910
	13.0	0.6	0.6	55	55	64	67	69	3	3	0.6	0.6	2007910 E
	17.0	1	1	–	–	–	–	–	4	6	1	1	2007110
	17.8	1	1	56	56	72	74	77	4	4.5	1	1	2007110 E
	17.0	1	1	56	56	72	74	76	4	5	1	1	3007110 E
	20.4	1.5	1.5	57	56	74	78	82	4	6	1.5	1.5	3007710 E
	20.0	1.5	1.5	57	58	79	83	86	3	5	1.5	1.5	7210 E
	21.0	1.5	1.5	57	57	78	83	86	3	6	1.5	1.5	7510 E
	23.2	1.5	1.5	57	57	77	83	87	5	7.5	1.5	1.5	3007210 E
	23.0	2.5	2	60	65	95	100	103	4	6.5	2	2	7310 E
34.8	2.5	2	60	58	87	100	105	4	10.5	2	2	27310 E	
28.2	2.5	2	60	61	90	100	102	5	9.5	2	2	7610 E	
55	14.3	1	1	61	60	71	74	77	3	3	1	1	2007911 E
	19.0	1.5	1.5	–	–	–	–	–	4	6	1.5	1.5	2007111
	19.8	1.5	1.5	62	63	81	83	86	4	5.5	1.5	1.5	2007111 E
	19.0	1.5	1.5	62	63	81	83	86	5	6	1.5	1.5	3007111 E
	21.9	1.5	1.5	62	62	83	88	91	5	7	1.5	1.5	3007711 E
	21.0	2	1.5	64	64	88	91	95	4	5	2	1.5	7211 E
	22.8	2	1.5	64	62	87	91	96	4	6	2	1.5	7511 E
	25.1	2	1.5	64	62	85	91	96	6	8	2	1.5	3007211 E
	24.9	2.5	2	65	70	104	110	112	4	6.5	2.5	2	7311 E
	37.5	2.5	2	65	63	94	110	114	4	10.5	2.5	2	27311 E
30.4	2.5	2	65	66	99	110	111	5	10	2.5	2	7611 E	
60	18.0	1	1	–	–	–	–	–	3	5	1	1	2007912
	15.1	1	1	66	65	75	79	82	3	3	1	1	20074912 E
	20.0	1.5	1.5	–	–	–	–	–	4	6	1.5	1.5	2007112
	20.9	1.5	1.5	67	67	85	88	91	4	5.5	1.5	1.5	2007112 E
	19.8	1.5	1.5	67	67	85	88	90	5	6	1.5	1.5	3007112 E
	23.1	1.5	1.5	67	67	88	93	96	5	7	1.5	1.5	3007712 E
	22.3	2	1.5	69	69	96	101	103	4	5	2	1.5	7212 E
	25.0	2	1.5	69	68	95	101	105	4	6	2	1.5	7512 E
	27.5	2	1.5	69	69	93	101	105	6	9	2	1.5	3007212 E
	26.6	3	2.5	72	76	112	118	121	5	7.5	2.5	2.1	7312 E

Metric series

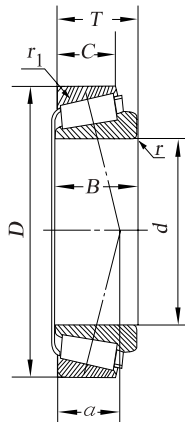

30000 Model

d 60 ~ 75mm

d	Boundary dimensions mm				Basic load ratings /kN		Limiting speeds /(r/min)		Mass /Kg	e	Y	Y_0	30000 Model	ISO355
	D	T	B	C	C_r	C_{or}	grease	oil	W ≈					
60	130	33.5	31	22	145	178	3200	4000	1.90	0.83	0.7	0.4	31312	7FB
	130	48.5	46	37	228	302	3200	4000	2.90	0.35	1.7	1	32312	2FD
65	90	17	17	14	45.5	73.2	3800	4800	0.295	0.35	1.7	0.9	32913	2BC
	100	23	22	19	67.0	102	3600	4500	0.63	0.35	1.7	0.9	32013 X2	-
	100	23	23	17.5	82.8	128	3600	4500	0.620	0.46	1.3	0.7	32013	4CC
	100	27	27	21	98.0	158	3600	4500	0.732	0.35	1.7	1	33013	2CE
	110	34	34	26.5	142	220	3400	4300	1.30	0.39	1.6	0.9	33113	3DE
	120	24.75	23	20	120	152	3200	4000	1.13	0.4	1.5	0.8	30213	3EB
	120	32.75	31	27	160	222	3200	4000	1.55	0.4	1.5	0.8	32213	3EC
	120	41	41	32	202	282	3200	4000	1.99	0.39	1.5	0.9	33213	3EE
	140	36	33	28	195	242	2800	3600	2.44	0.35	1.7	1	30313	2GB
	140	36	33	23	165	202	2800	3600	2.37	0.83	0.7	0.4	31313	7GB
70	140	51	48	39	260	350	2800	3600	3.51	0.35	1.7	1	32313	2GD
	100	20	19	16	53.2	85.5	3600	4500	-	0.33	1.8	1	32914 X2	-
	100	20	20	16	70.8	115	3600	4500	0.471	0.32	1.9	1	32914	2BC
	110	25	24	20	83.8	128	3400	4300	0.85	0.34	1.8	1	32014 X2	-
	110	25	25	19	105	160	3400	4300	0.839	0.43	1.4	0.8	32014	4CC
	110	31	31	25.5	135	220	3400	4300	1.07	0.28	2	1	33014	2CE
	120	37	37	29	172	368	3200	4000	1.70	0.39	1.5	1.2	33114	3DE
	125	26.25	24	21	132	175	3000	3800	1.26	0.42	1.4	0.8	30214	3EB
	125	33.25	31	27	168	238	3000	3800	1.64	0.42	1.4	0.8	32214	3EC
	125	41	41	32	208	298	3000	3800	2.10	0.41	1.5	0.8	33214	3EE
	150	38	35	30	218	272	2600	3400	2.98	0.35	1.7	1	30314	2GB
	150	38	35	25	188	230	2600	3400	2.86	0.83	0.7	0.4	31314	7GB
	150	54	51	42	298	408	2600	3400	4.34	0.35	1.7	1	32314	2GD
	75	105	20	20	16	78.2	125	3400	4300	0.490	0.33	1.8	1	32915
115		25	24	20	85.2	135	3200	4000	0.88	0.35	1.7	0.9	32015 X2	-
115		25	25	19	102	160	3200	4000	0.875	0.46	1.3	0.7	32015	4CC
115		31	31	25.5	132	220	3200	4000	1.12	0.3	2	1	33015	2CE
125		37	37	29	175	280	3000	3800	1.78	0.4	1.5	0.8	33115	3DE
130		27.25	25	22	138	185	2800	3600	1.36	0.44	1.4	0.8	30215	4DB
130		33.25	31	27	170	242	2800	3600	1.74	0.44	1.4	0.8	32215	4DC
130		41	41	31	208	300	2800	3600	2.17	0.43	1.4	0.8	33215	3EE
160		40	37	31	252	318	2400	3200	3.57	0.35	1.7	1	30315	2GB
160		40	37	26	208	258	2400	3200	3.38	0.83	0.7	0.4	31315	7GB

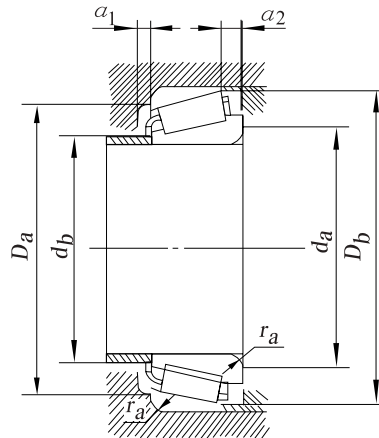

d	a ≈	r_s min	r_{1s} min	d_a min	d_b max	D_a min	D_a max	D_b min	a_1 min	a_2 min	r_{as} max	r_{bs} max	
60	40.4	3	2.5	72	69	103	118	124	5	11.5	2.5	2.1	273012 E
	32.0	3	2.5	72	72	107	118	122	6	11.5	2.5	2.1	7612 E
65	16.2	1	1	71	70	80	84	87	3	3	1	1	2007913 E
	21.0	1.5	1.5	–	–	–	–	–	4	6	1.5	1.5	2007113
	22.4	1.5	1.5	72	72	90	93	97	4	5.5	1.5	1.5	2007113 E
	20.9	1.5	1.5	72	72	89	93	96	5	6	1.5	1.5	3007113 E
	26.0	1.5	1.5	72	73	96	103	106	6	7.5	1.5	1.5	3007713 E
	23.8	2	1.5	74	77	106	111	114	4	5	2	1.5	7213 E
	27.3	2	1.5	74	75	104	111	115	4	6	2	1.5	7513 E
	29.5	2	1.5	74	74	102	111	115	7	9	2	1.5	3007213 E
	28.7	3	2.5	77	83	122	128	131	5	8	2.5	2.1	7313 E
	44.2	3	2.5	77	75	111	128	134	5	13	2.5	2.1	27313 E
70	34.3	3	2.5	77	79	117	128	131	6	12	2.5	2.1	7613 E
	19.0	1	1	–	–	–	–	–	4	6	1	1	2007914
	17.6	1	1	76	76	90	94	96	4	4	1	1	2007914 E
	23.0	1.5	1.5	–	–	–	–	–	5	7	1.5	1.5	2007114
	23.8	1.5	1.5	77	78	98	103	105	5	6	1.5	1.5	2007114 E
	22.0	1.5	1.5	77	79	99	103	105	5	5.5	1.5	1.5	3007114 E
	28.2	2	1.5	79	79	104	111	115	6	8	2	1.5	3007714 E
	25.8	2	1.5	79	81	110	116	119	4	5.5	2	1.5	7214 E
	28.8	2	1.5	79	79	108	116	120	4	6.5	2	1.5	7514 E
	30.7	2	1.5	79	79	107	116	120	7	9	2	1.5	3007214 E
	30.7	3	2.5	82	89	130	138	141	5	8	2.5	2.1	7314 E
	46.8	3	2.5	82	80	118	138	143	5	13	2.5	2.1	27314 E
	75	36.5	3	2.5	82	84	125	138	141	6	12	2.5	2.1
18.5		1	1	81	81	94	99	102	4	4	1	1	2007915 E
24.0		1.5	1.5	–	–	–	–	–	5	7	1.5	1.5	2007115
25.2		1.5	1.5	82	83	103	108	110	5	6	1.5	1.5	2007115 E
22.8		1.5	1.5	82	83	103	108	110	6	5.5	1.5	1.5	3007115 E
29.4		2	1.5	84	84	109	116	120	6	8	2	1.5	3007715 E
27.4		2	1.5	84	85	115	121	125	4	5.5	2	1.5	7215 E
30.3		2	1.5	84	84	115	121	126	4	6.5	2	1.5	7515 E
31.9		2	1.5	84	83	111	121	125	7	10	2	1.5	3007215 E
32.0		3	2.5	87	95	139	148	150	5	9	2.5	2.1	7315 E
49.7	3	2.5	87	86	127	148	153	6	14	2.5	2.1	27315 E	

Metric series

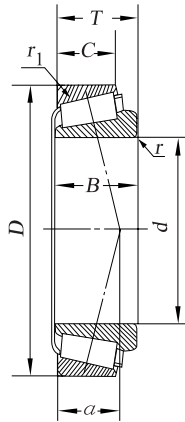

30000 Model

d 75 ~ 90mm

d	Boundary dimensions mm				Basic load ratings /kN		Limiting speeds /(r/min)		Mass /Kg	e	Y	Y ₀	30000 Model	ISO355
	D	T	B	C	C _r	C _{or}	grease	oil	W ≈					
75	160	58	55	45	348	482	2400	3200	5.37	0.35	1.7	1	32315	2GD
80	110	20	20	16	79.2	128	3200	4000	0.514	.035	1.7	0.9	32916	2BC
	125	29	27	23	102	162	3000	3800	1.18	.034	1.8	1	32016 X2	-
	125	29	29	22	140	220	3000	3800	1.27	0.42	1.4	0.8	32016	3CC
	125	36	36	29.5	182	305	3000	3800	1.63	0.28	2.2	1.2	33016	2CE
	130	37	37	29	180	292	2800	3600	1.87	0.42	1.4	0.8	33116	3DE
	140	28.25	26	22	160	212	2600	3400	1.67	0.42	1.4	0.8	30216	3EB
	140	35.25	33	28	198	278	2600	3400	2.13	0.42	1.4	0.8	32216	3EC
	140	46	46	35	245	362	2600	3400	2.83	0.43	1.4	0.8	33216	3EE
	170	42.5	39	33	278	352	2200	3000	4.27	0.35	1.7	1	30316	2GB
	170	42.5	39	27	230	288	2200	3000	4.05	0.83	0.7	0.4	31316	7GB
85	170	61.5	58	48	388	542	2200	3000	6.38	0.35	1.7	1	32316	2GD
	120	23	22	29	74.2	125	3400	3800	0.73	0.26	2.3	1.3	32917 X2	-
	120	23	23	18	96.8	165	3400	3800	0.767	0.33	1.8	1	32917	2BC
	130	29	27	23	105	170	2800	3600	1.25	0.35	1.7	0.9	32017 X2	-
	130	29	29	22	140	220	2800	3600	1.32	0.44	1.4	0.8	32017	4CC
	130	36	36	29.5	180	305	2800	3600	1.69	0.29	2.1	1.1	33017	2CE
	140	41	41	32	215	355	2600	3400	2.43	0.41	1.5	0.8	33117	3DE
	150	30.5	28	24	178	238	2400	3200	2.06	0.42	1.4	0.8	30217	3EB
	150	38.5	36	30	228	325	2400	3200	2.68	0.42	1.4	0.8	32217	3EC
	150	49	49	37	282	415	2400	3200	3.52	0.42	1.4	0.8	33217	3EE
90	180	44.5	41	34	305	388	2000	2800	4.96	0.35	1.7	1	30317	3GB
	180	44.5	41	28	255	318	2000	2800	4.96	0.83	0.7	0.4	31317	7GB
	180	63.5	60	49	422	592	2000	2800	7.31	0.35	1.7	1	32317	2GD
	125	23	22	19	77.8	140	3200	3600	-	0.38	1.6	0.9	32918 X2	-
	125	23	23	18	95.8	165	3200	3600	0.796	0.34	1.8	1	32918	2BC
	140	32	30	26	122	192	2600	3400	1.7	0.34	1.8	1	32018 X2	-
	140	32	32	24	170	270	2600	3400	1.72	0.42	1.4	0.8	32018	3CC
	140	39	39	32.5	232	388	2600	3400	2.20	0.27	2.2	1.2	33018	2CE
	150	45	45	35	252	415	2400	3200	3.13	0.4	1.5	0.8	33118	3DE
	160	32.5	30	26	200	270	2200	3000	2.54	0.42	1.4	0.8	30218	3FB
90	160	42.5	40	34	270	395	2200	3000	3.44	0.42	1.4	0.8	32218	3FC
	160	55	55	42	330	500	2200	3000	4.55	0.4	1.5	0.8	33218	3FE
	190	46.5	43	36	342	440	1900	2600	5.80	0.35	1.7	1	30318	2GB
	190	46.5	43	30	282	358	1900	2600	5.46	0.83	0.7	0.4	31318	7GB

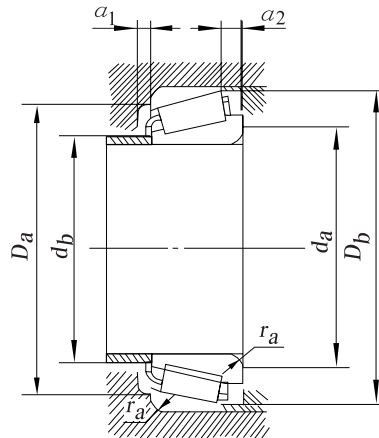

<i>d</i>	<i>a</i> ≈	<i>r_s</i> min	<i>r_{1s}</i> min	<i>d_a</i> min	<i>d_b</i> max	<i>D_a</i> min	<i>D_a</i> max	<i>D_b</i> min	<i>a₁</i> min	<i>a₂</i> min	<i>r_{as}</i> max	<i>r_{bs}</i> max		
75	39.4	3	2.5	87	91	133	148	150	7	13	2.5	2.1	7615 E	
80	19.6	1	1	86	85	99	104	107	4	4	1	1	2007916 E	
	26.0	1.5	1.5	—	—	—	—	—	5	8	1.5	1.5	2007116	
	26.8	1.5	1.5	87	89	112	117	120	6	7	1.5	1.5	7007116 E	
	25.2	1.5	1.5	87	80	112	117	119	6	7	1.5	1.5	3007116 E	
	30.7	2	1.5	89	89	114	121	126	6	8	2	1.5	3007716 E	
	28.1	2.5	2	90	90	124	130	133	4	6	2.1	2	7216 E	
	31.4	2.5	2	90	89	122	130	135	5	7.5	2.1	2	7516 E	
	35.1	2.5	2	90	89	119	130	135	7	11	2.1	2	3007216 E	
	34.4	3	2.5	92	102	148	158	160	5	9.5	2.5	2.1	7316 E	
	52.8	3	2.5	92	91	134	158	161	6	15.5	2.5	2.1	27316 E	
85	42.1	3	2.5	92	97	142	158	160	7	13.5	2.5	2.1	7616 E	
	21.0	1.5	1.5	—	—	—	—	—	4	6	1.5	1.5	2007917	
	21.1	1.5	1.5	92	92	111	113	115	4	5	1.5	1.5	2007917 E	
	27.0	1.5	1.5	—	—	—	—	—	5	8	1.5	1.5	2007117	
	28.1	1.5	1.5	92	94	117	122	125	6	7	1.5	1.5	2007117 E	
	26.2	1.5	1.5	92	94	118	122	125	6	6.5	1.5	1.5	3007117 E	
	33.1	2.5	2	95	95	122	130	135	7	9	2.1	2	3007717 E	
	30.3	2.5	2	95	96	132	140	142	5	6.5	2.1	2	7217 E	
	33.9	2.5	2	95	95	130	140	143	5	8.5	2.1	2	7517 E	
	36.9	2.5	2	95	95	128	140	144	7	12	2.1	2	3007217 E	
	35.9	4	3	99	107	156	166	168	6	10.5	3	2.5	7317 E	
	55.6	4	3	99	96	143	166	171	6	16.5	3	2.5	27317 E	
	43.5	4	3	99	102	150	166	168	8	14.5	3	2.5	7617 E	
	90	25.0	1.5	1.5	—	—	—	—	—	4	6	1.5	1.5	2007918
		22.2	1.5	1.5	97	96	113	117	121	4	5	1.5	1.5	2007918 E
29.0		2	1.5	—	—	—	—	—	5	8	2	1.5	2007118	
30.0		2	1.5	99	100	125	131	134	6	8	2	1.5	2007118 E	
27.2		2	1.5	99	100	127	131	135	7	6.5	2	1.5	3007118 E	
34.9		2.5	2	100	100	130	140	144	7	10	2.1	2	3007718 E	
32.3		2.5	2	100	102	140	150	151	5	6.5	2.1	2	7218 E	
36.8		2.5	2	100	101	138	150	153	5	8.5	2.1	2	7518 E	
40.8		2.5	2	100	100	134	150	154	8	13	2.1	2	3007218 E	
37.5		4	3	104	113	165	176	178	6	10.5	3	2.5	7318 E	
58.5	4	3	104	102	151	176	181	6	16.5	3	2.5	27318 E		

Metric series

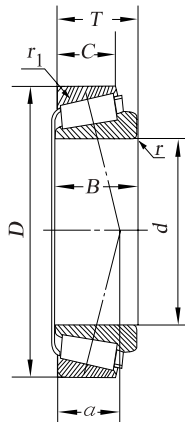

30000 Model

d 90 ~ 105mm

d	Boundary dimensions mm				Basic load ratings /kN		Limiting speeds /(r/min)		Mass /Kg		e	Y	Y_0	30000 Model	ISO355
	D	T	B	C	C_r	C_{or}	grease	oil	W ≈						
90	180	67.5	64	53	478	682	1900	2600	8.81	0.35	1.7	1	32318	2GD	
95	130	23	23	18	97.2	170	2600	3400	0.831	0.36	1.7	0.9	32919	2BC	
	145	32	30	26	122	192	2400	3200	1.7	0.36	1.7	0.9	32019X2	-	
	145	32	32	24	175	280	2400	3200	1.79	0.44	1.4	0.8	32109	4CC	
	145	39	39	32.5	230	390	2400	3200	2.26	0.28	2.2	1.2	33019	2CE	
	160	49	49	38	298	498	2200	3000	3.94	0.39	1.5	0.8	33119	3EE	
	170	34.5	32	27	228	308	2000	2800	3.04	0.42	1.4	0.8	30219	3FB	
	170	45.5	43	37	302	448	2000	2800	4.24	0.42	1.4	0.8	32219	3FC	
	170	58	58	44	378	568	2000	2800	5.48	0.41	1.5	0.8	33219	3FE	
	200	49.5	45	38	370	478	1800	2400	6.80	0.35	1.7	1	30319	2GB	
	200	49.5	45	32	310	400	1800	2400	6.46	0.83	0.7	0.4	31319	7GB	
100	200	71.5	67	55	515	738	1800	2400	10.1	0.35	1.7	1	32319	2GD	
	140	25	25	20	128	218	2400	3200	1.12	0.33	1.8	1	32920	2CC	
	150	32	30	26	125	205	2200	3000	1.79	0.37	1.6	0.9	32020X2	-	
	150	32	32	24	172	282	2200	3000	1.85	0.46	1.3	0.7	32020	4CC	
	150	39	39	32.5	230	390	2200	3000	2.33	0.29	2.1	1.2	33020	2CE	
	165	52	52	40	308	528	2000	2800	4.31	0.41	1.5	0.8	33120	3EE	
	180	37	34	29	255	350	1900	2600	3.72	0.42	1.4	0.8	30220	3FB	
	180	49	46	39	340	512	1900	2600	5.10	0.42	1.4	0.8	32220	3FC	
	180	63	63	48	438	665	1900	2600	6.71	0.4	1.5	0.8	33220	3FE	
	215	51.5	47	39	405	525	1600	2000	8.22	0.35	1.7	1	30320	2GB	
105	215	56.5	51	35	372	488	1600	2000	8.59	0.83	0.7	0.4	31320	7GB	
	215	77.5	73	60	600	872	1600	2000	13.0	0.35	1.7	1	32320	2GD	
	145	25	25	20	128	225	2200	3000	1.16	0.34	1.8	1	32921	2CC	
	160	35	33	28	162	270	2000	2800	2.5	0.36	1.7	0.9	32021X2	-	
	160	35	35	26	205	335	2000	2800	2.40	0.44	1.4	0.7	32021	4DC	
	160	43	43	34	258	438	2000	2800	2.97	0.28	2.1	1.2	33021	2DE	
	175	56	56	44	352	608	1900	2600	5.29	0.4	1.5	0.8	33121	3FE	
	190	39	36	30	285	398	1800	2400	4.38	0.42	1.4	0.8	30221	3FB	
	190	53	50	43	380	578	1800	2400	6.26	0.42	1.4	0.8	32221	3FC	
	190	68	68	52	498	770	1800	2400	8.12	0.4	1.5	0.8	33221	3FE	
110	225	53.5	49	41	432	562	1500	1900	9.38	0.35	1.7	1	30321	2GB	
	225	58	53	36	398	525	1500	1900	9.58	0.83	0.7	0.4	31321	7GB	
	225	81.5	77	63	648	945	1500	1900	14.8	0.35	1.7	1	32321	2GD	

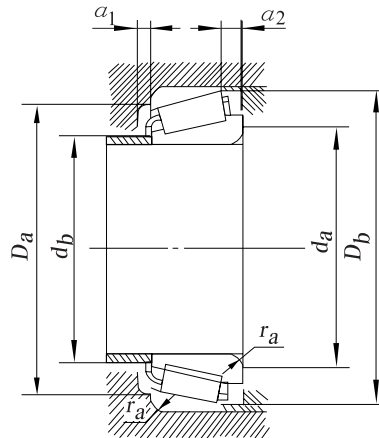

<i>d</i>	<i>a</i> ≈	<i>r_s</i> min	<i>r_{1s}</i> min	<i>d_a</i> min	<i>d_b</i> max	<i>D_{ab}</i> min	<i>D_a</i> max	<i>D</i> min	<i>a₁</i> min	<i>a₂</i> min	<i>r_{as}</i> max	<i>r_{bs}</i> max	
90	46.2	4	3	104	107	157	176	178	8	14.5	3	2.5	7618 E
95	23.4	1.5	1.5	102	101	117	122	126	4	5	1.5	1.5	2007919 E
	30.0	2	1.5	—	—	—	—	—	5	8	2	1.5	2007119
	31.4	2	1.5	104	105	130	136	140	6	8	2	1.5	2007119 E
	28.4	2	1.5	104	104	131	136	139	7	6.5	2	1.5	3007119 E
	37.3	2.5	2	105	105	138	150	154	7	11	2.1	2	3007719 E
	34.2	3	2.5	107	108	149	158	160	5	7.5	2.5	2.1	7219 E
	39.2	3	2.5	107	106	145	158	163	5	8.5	2.5	2.1	7519 E
	42.7	3	2.5	107	105	144	158	163	9	14	2.5	2.1	3007219 E
	40.1	4	3	109	118	172	186	185	6	11.5	3	2.5	7319 E
	61.2	4	3	109	107	157	186	189	6	17.5	3	2.5	27319 E
100	49.0	4	3	109	114	166	186	187	8	16.5	3	2.5	7619 E
	24.3	1.5	1.5	107	108	128	132	136	4	5	1.5	1.5	2007920 E
	32.0	2	1.5	—	—	—	—	—	5	8	2	1.5	2007120
	32.8	2	1.5	109	109	134	141	144	6	8	2	1.5	2007120 E
	29.1	2	1.5	109	108	135	141	143	7	6.5	2	1.5	3007120 E
	40.3	2.5	2	110	110	142	155	159	8	12	2.1	2	3007720 E
	36.4	3	2.5	112	114	157	168	169	5	8	2.5	2.1	7220 E
	41.9	3	2.5	112	113	154	168	172	5	10	2.5	2.1	7520 E
	45.5	3	2.5	112	112	151	168	172	10	15	2.5	2.1	3007220 E
	42.2	4	3	114	127	184	201	199	6	12.5	3	2.5	7320 E
105	68.4	4	3	114	115	168	201	204	7	21.5	3	2.5	27320 E
	52.9	4	3	114	122	177	201	201	8	17.5	3	2.5	7620 E
	25.4	1.5	1.5	112	112	132	137	141	5	5	1.5	1.5	2007921 E
	33.0	2.5	2	—	—	—	—	—	6	9	2.1	2	2007121
	34.6	2.5	2	115	116	142	150	154	6	9	2.1	2	2007121 E
	30.8	2.5	2	115	116	145	150	153	7	9	2.1	2	3007121 E
	42.9	2.5	2	115	115	149	165	170	8	12	2.1	2	3007721 E
	38.5	3	2.5	117	121	165	178	178	6	9	2.5	2.1	7221 E
	45.0	3	2.5	117	118	161	178	182	5	10	2.5	2.1	7521 E
	48.6	3	2.5	117	117	159	178	182	12	16	2.5	2.1	3007221 E
110	43.6	4	3	119	133	193	211	208	7	12.5	3	2.5	7321 E
	70.0	4	3	119	121	176	211	213	7	22	3	2.5	27321 E
	55.1	4	3	119	128	185	211	210	8	18.5	3	2.5	7621 E



GMB Corporation (JAPAN)

No. 150-3, Handa, Kawanishi-cho, Shiki-gun
Nara 636-0295
Tel. 81-745-44-1911 / Fax. 81-745-44-1930

GMB North America Inc. (U.S.A)

West Office(California)

2725 EL Presidio Street, Carson, CA90810
Tel. 1-310-631-7555 / Fax. 1-310-631-5795

East Office(New Jersey)

200 Herrod Blvd, Deylon, NJ08810
Tel. 1-609-655-2422 / Fax. 1-609-655-2257

GMB KOREA Corporation

#53, Sungsan-dong, Changwon-city,
Kyungnam-do (641-315)
Tel. 82-55-279-1313 / Fax. 82-55-261-1615
<http://www.gmb.co.kr>

